

REALISTIC[®]

Service Manual

20-119/9119

PRO-2004

PROGRAMMABLE SCANNER

GENERAL COVERAGE

AM/FM MONITOR RECEIVER

Catalog Number: 20-119/9119

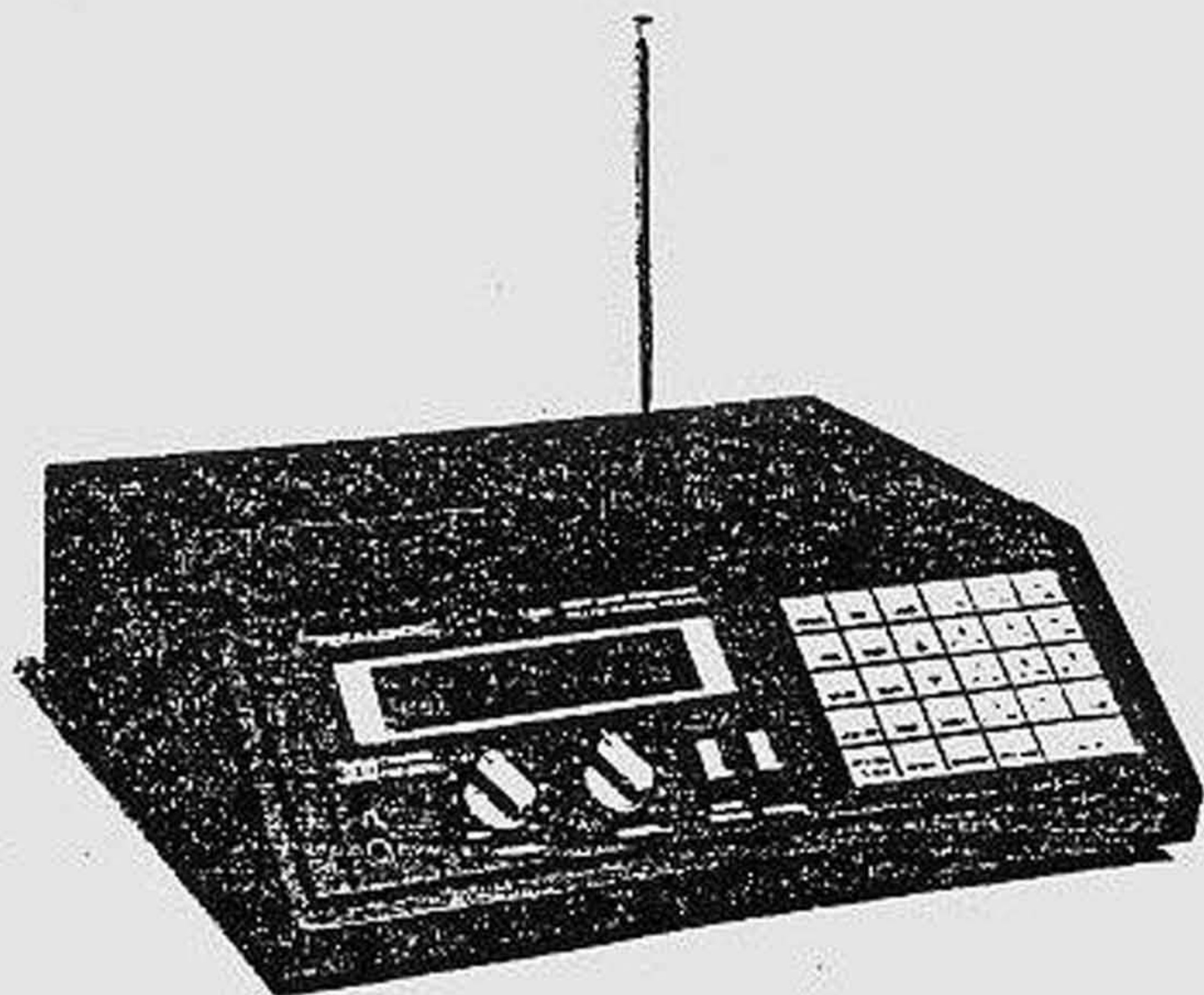

CUSTOM MANUFACTURED FOR RADIO SHACK, A DIVISION OF TANDY CORPORATION

CONTENTS

SPECIFICATIONS	3
BLOCK DIAGRAM.....	5
PRINCIPLES OF OPERATION	6
GENERAL OPERATION OUTLINE	7
ALIGNMENT	9
RECEPTION CHECK	19
MEMORY CHECK	20
TROUBLE SHOOTING	21
P. C. BOARDS (TOP AND BOTTOM VIEWS)	24
WIRING DIAGRAM.....	31
ELECTRICAL PARTS LIST.....	32
MECHANICAL PARTS LIST	53
APPENDIX.....	54
DISASSEMBLY/EXPLODED VIEW.....	55
SEMICONDUCTOR LEAD IDENTIFICATION AND IC CIRCUIT DIAGRAM.....	57
MICROPROCESSOR (IC-503) PIN ALLOCATION	67
SCHEMATIC DIAGRAM	70

PRODUCT SAFETY NOTICE

Many electrical and mechanical parts in this chassis have special characteristics. These characteristics often pass unnoticed and the protection afforded by them cannot necessarily be obtained by using replacement components rated for higher voltage, wattage, etc. Replacement parts that have these special safety characteristics are identified in this manual and its supplements; electrical components having such features are identified by a Δ in the schematic diagram and the parts list.

Before replacing any of these components, read the parts list in this manual carefully. The use of substitute replacement parts that do not have the same safety characteristics as specified in the parts list may create shock, fire or other hazards.

SPECIFICATIONS

DESCRIPTION	NOMINAL SPEC.	LIMIT SPEC.
Frequency Range		25 to 520 MHz 760 to 1300 MHz
Sensitivity		
NFM: 20 dB S/N at 3 kHz DEV. 1 kHz		
25 to 520 MHz	0.5 μ V	2.0 μ V
760 to 1100 MHz	0.5 μ V	2.0 μ V
1100 to 1300 MHz	3.0 μ V	10.0 μ V
AM: 20 dB S/N at 60% MOD. 1 kHz		
25 to 520 MHz	2.0 μ V	5.0 μ V
760 to 1100 MHz	2.0 μ V	5.0 μ V
1100 to 1300 MHz	3.0 μ V	10.0 μ V
WFM: 30 dB S/N at 22.5 kHz DEV. 1 kHz		
25 to 520 MHz	3.0 μ V	10.0 μ V
760 to 1100 MHz	3.0 μ V	10.0 μ V
1100 to 1300 MHz	10.0 μ V	20.0 μ V
Selectivity		
NFM/AM		
-6 dB	\pm 9 kHz	\pm 12 kHz
-50 dB	\pm 15 kHz	\pm 18 kHz
WFM		
-6 dB	\pm 150 kHz	\pm 200 kHz
-50 dB	\pm 300 kHz	\pm 400 kHz
Modulation Acceptance: EIA RS-204-A		
Spurious Rejection		
Image Ratio at 328 MHz (NFM)	40 dB	35 dB
at 70 MHz (NFM)	35 dB	25 dB
70 MHz + (2x610 MHz)		
= 1290 MHz		
IF Rejection		
610 MHz at 70 MHz (NFM)	60 dB	40 dB
608 MHz at 1000 MHz (NFM)	60 dB	40 dB
Signal to Noise Ratio		
NFM/AM	40 dB	30 dB
3 kHz DEV. at 1 kHz		
60% MOD. at 1 kHz		
100 μ V INPUT		
WFM	45 dB	35 dB
22.5 kHz DEV. at 1 kHz		
Squelch Sensitivity		
NFM/AM		
Threshold 25 to 520 MHz	0.5 μ V	2.0 μ V
760 to 1100 MHz	0.5 μ V	2.0 μ V
1100 to 1300 MHz	3.0 μ V	10.0 μ V
Tight (S + N/N)	25 dB	15 dB
WFM		
Threshold 25 to 520 MHz	3.0 μ V	10.0 μ V
760 to 1100 MHz	3.0 μ V	10.0 μ V
1100 to 1300 MHz	10.0 μ V	20.0 μ V
Tight (S + N/N)	40 dB	30 dB
Scanning Rate		
Fast	16 channel/sec.	14 to 18 channel/sec.
Slow	8 channel/sec.	7 to 9 channel/sec.

<p>Search Rate</p> <p style="text-align: right;">Fast Slow</p> <p>Residual Noise (Vol. Min.) Priority Sampling Scan Delay Time Audio Output Power (T.H.D. 10%) Tape Output MOD. and DEV: NFM 3 kHz DEV. at 1 kHz AM 60% MOD. at 1 kHz WFM 45 kHz DEV. at 1 kHz LOAD: 10 k ohm INPUT: 100 μV LOW BATT Indicator</p>	<p>16 steps/sec. 8 steps/sec. 3 mV 2 sec. 2 sec. 1.8 W</p> <p>600 mV</p> <p>4.5 V</p>	<p>14 to 18 steps/sec. 7 to 9 steps/sec. 5 mV 1.5 to 2.5 sec. 1.5 to 2.5 sec. 1.3 W</p> <p>300 mV</p> <p>4.5 \pm 0.5 V</p>
<p>Channels of Operation</p> <p>Channel, Frequency and Mode Display Receiving System</p> <p>Power Source</p> <p>Speaker Dimensions</p> <p>Weight</p>	<p>Any 300 channels in any band combination (30 channels x 10 banks), and 10 Monitor channels.</p> <p>Liquid crystal display Direct Key Entry Digital Controlled Synthesizer, Superheterodyne. AC 120 V, 60 Hz, 20 W max. DC 13.8 V, 12 W max. Built-in 3" (77 mm) 8 ohm Dynamic Speaker Approx. 2-7/8" (75 mm) x 10-1/4" (275 mm) x 9" (230 mm) HWD 7.0 lbs (3.2 kg.)</p>	

NOTE: *Nominal Specs represent the design specs: all units should be able to approximate these — some will exceed and some may drop slightly below these specs. Limit Specs represent the absolute worst condition that still might be considered acceptable; in no case should a unit perform to less than within any Limit Spec.*

PRINCIPLES OF OPERATION

The PRO-2004 is a Phase Locked Loop (PLL) synthesized VHF/UHF, AM/FM Receiver controlled by a Central Processing Unit (CPU) via the keyboard.

Receiving mode and search step are initially set to correspond with the frequencies entered. When a frequency within FM broadcast band is keyed in, receiving mode is set to Wideband FM (WFM). When a frequency in Action radio band, Police, Fire, Ambulance, Ham radio etc. is keyed in, the mode is set to Narrowband FM (NFM), and when a frequency in Aircraft and CB band is keyed in, it sets to AM mode. Also the mode and step can be changed by **MODE**, **STEP** Keys.

The CPU (IC-503) controls receiving frequency range, frequency determination, scanning speed, delay time, etc. The CPU is able to do only the assigned functions, and no modification of the CPU is feasible.

The following paragraphs explain the operation of the circuit in terms of the functional blocks:

RF input circuit comprises 10 dB attenuator and Bandpass filter. A signal generated by VCO-1 or VCO-2 is applied to Double balanced mixer (D.B.M.) via Low-pass or High-pass filter and mixed with the RF signal. The D.B.M. is employed to facilitates 25 MHz to 1300 MHz mixing.

The 1st IF (Q5) is 607.505 MHz to 611.500 MHz, and the signal is mixed with VCO-3 frequency at the 2nd mixer (Q6) to produce 48.5 MHz signal, which is applied to WFM IF (Q12) or AM/NFM IF (Q10, Q18, Q19). Corresponding with input from the keyboard, CPU determines which of VCO-1 or VCO-2, WFM IF, AM/NFM, AM IF, Data of PLL circuit to be functioned, and outputs the necessary data.

A signal entered to AM/NFM IF is mixed with X'tal oscillation frequency 48.045 MHz at the 3rd mixer (IC-2) and converted to 455 kHz signal. A signal entered to WFM IF is mixed with X'tal oscillation frequency 37.8 MHz at the 3rd mixer (Q13) and converted to 10.7 MHz signal. The signals are further amplified and detected to AF signal.

AF signals of WFM, AM, NFM are CPU controlled and applied to AF Power Amplifier (IC-7) via switching circuit. Squelch signal is comprised of noise product from WFM/NFM detector output, and amplified by IC-2 to switching signal, which controls AF mute and CPU.

Any unstable supply voltage to the CPU can produce CPU malfunctions, such as wrong data processing, wrong data transfer, etc. To overcome this C512 and R501 "initialize" the CPU. Initialization is done when RESTART switch is pushed. Figure A shows initializing waveform.

CX501 (7.37 MHz) is a clock which is used for CPU control. Figure B shows 1/4 divided waveform at Pin 31 of IC-503.

CPU output data display frequency, function, etc. on LCD. LCD is back lighted with Electro Luminescence, which works from 70 V rms, 300 Hz A.C.

Power supply comprises D.C 30 V, 8 V and two 5 V lines.

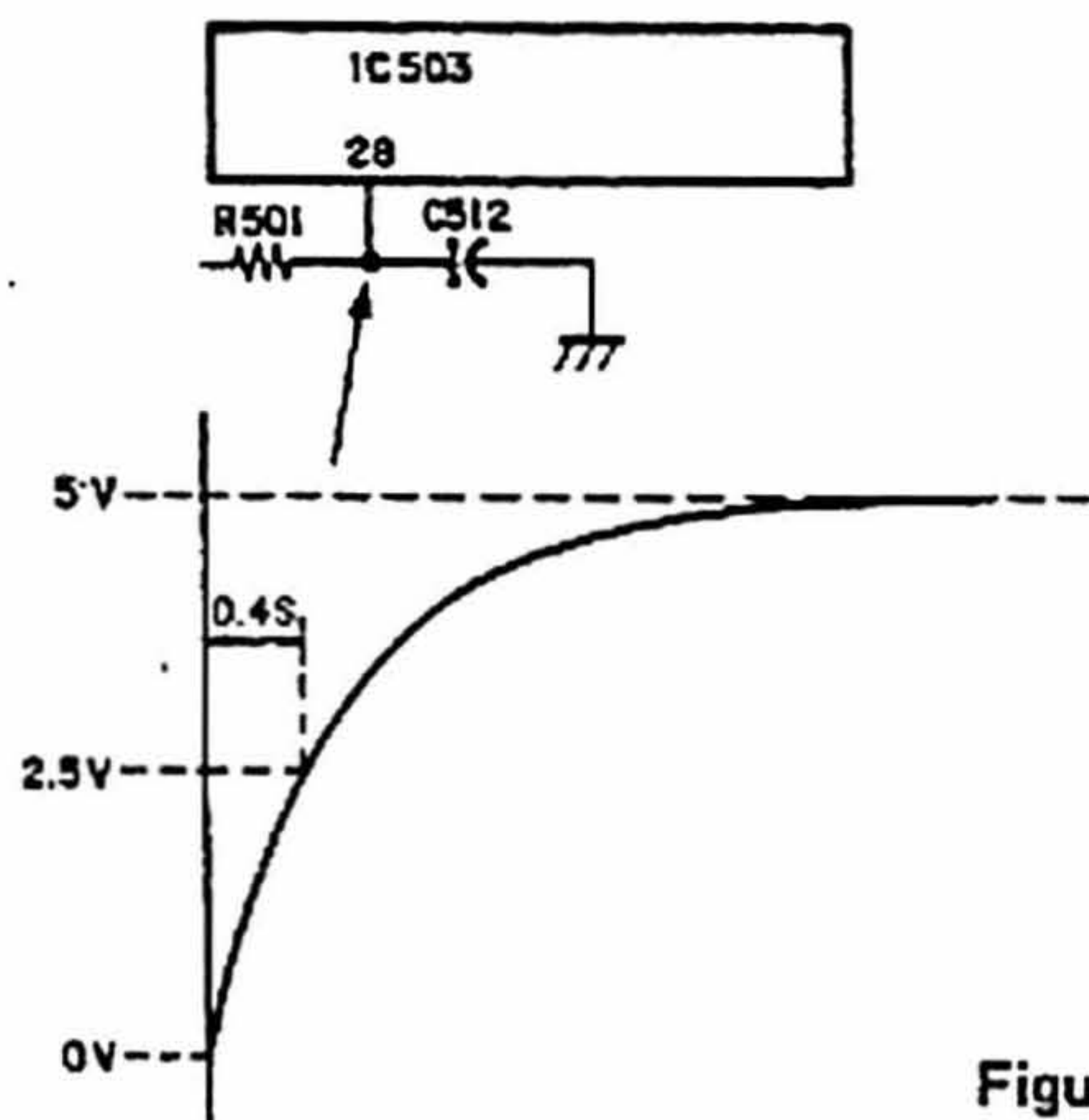

Figure A

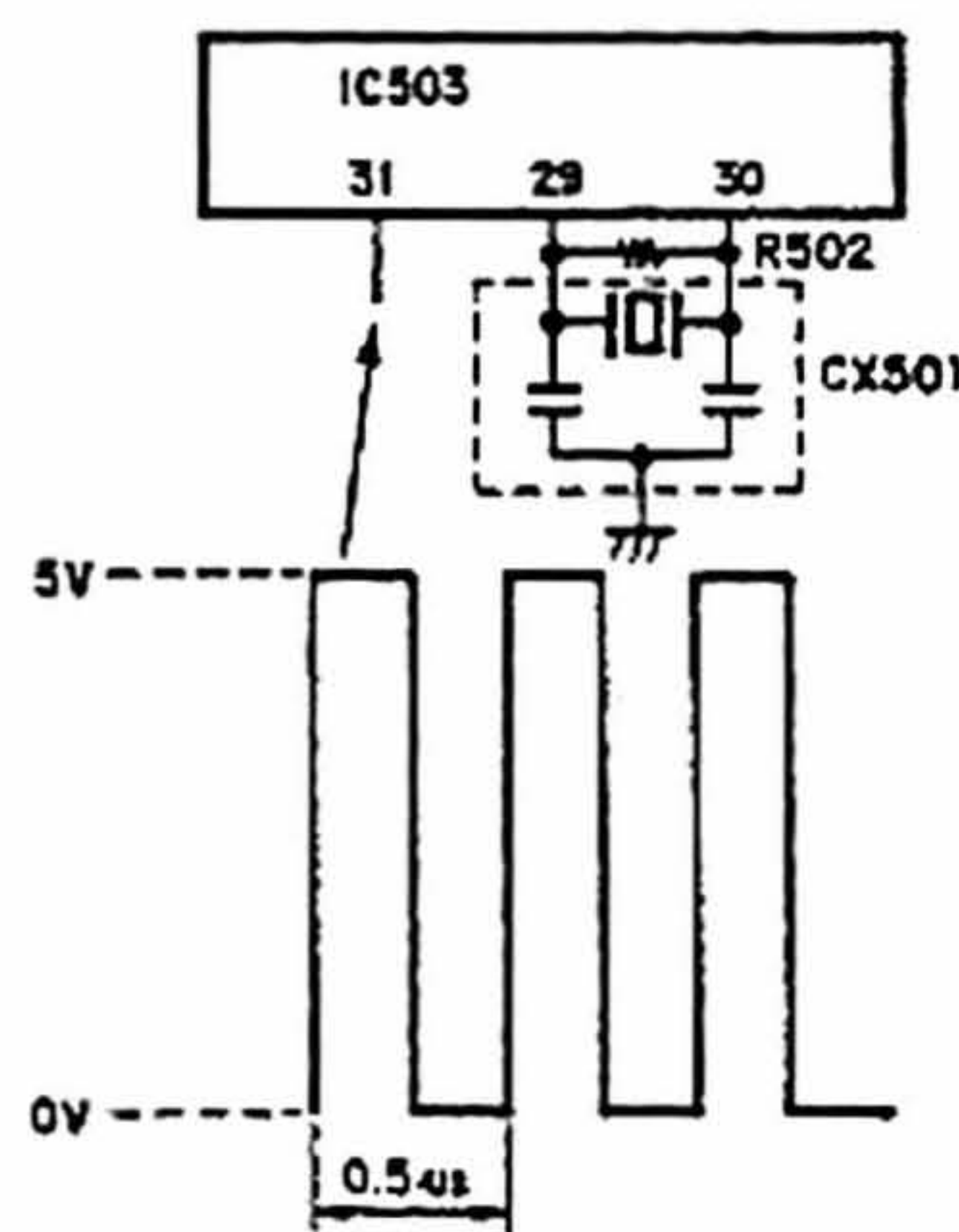
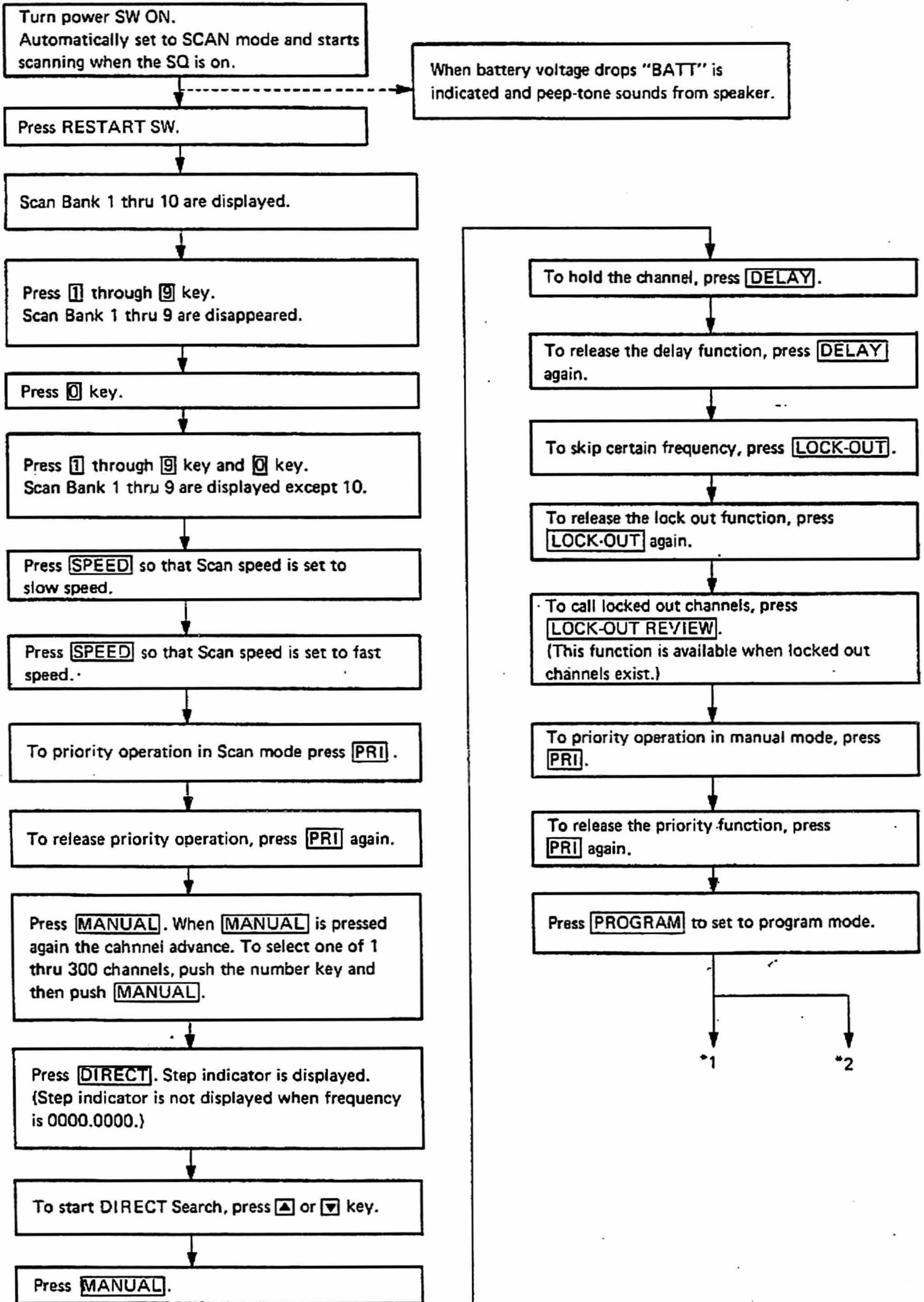
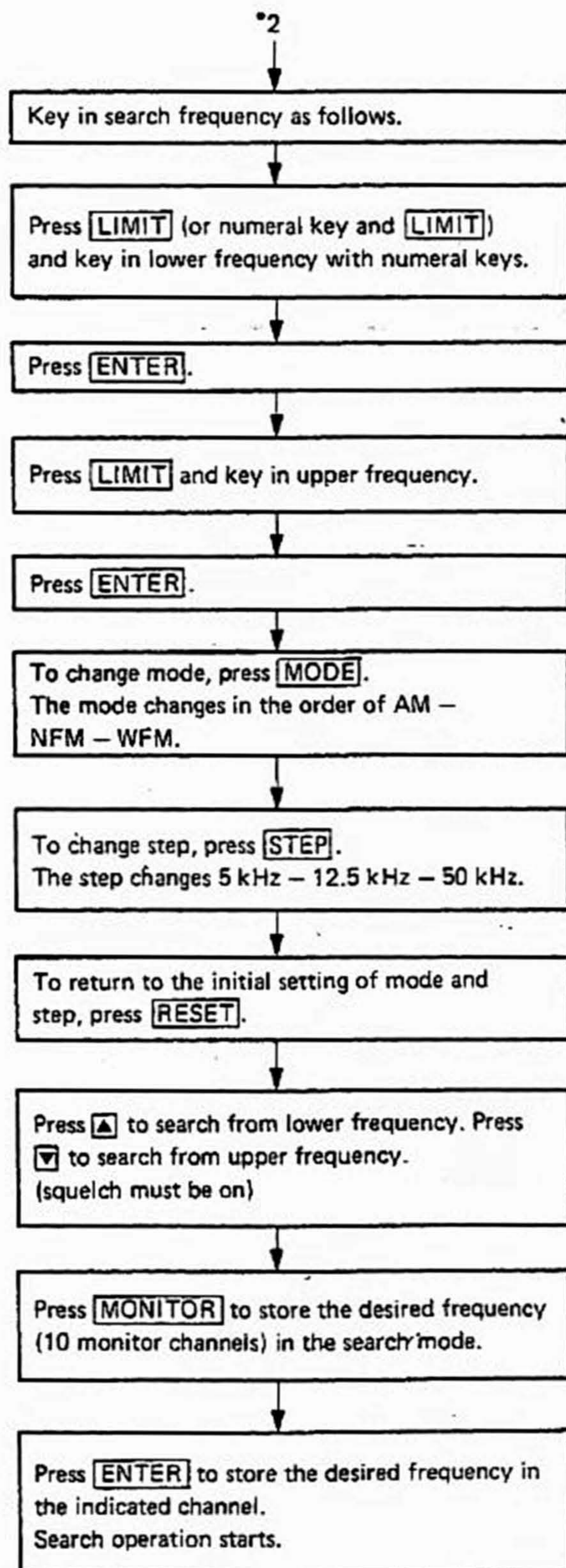
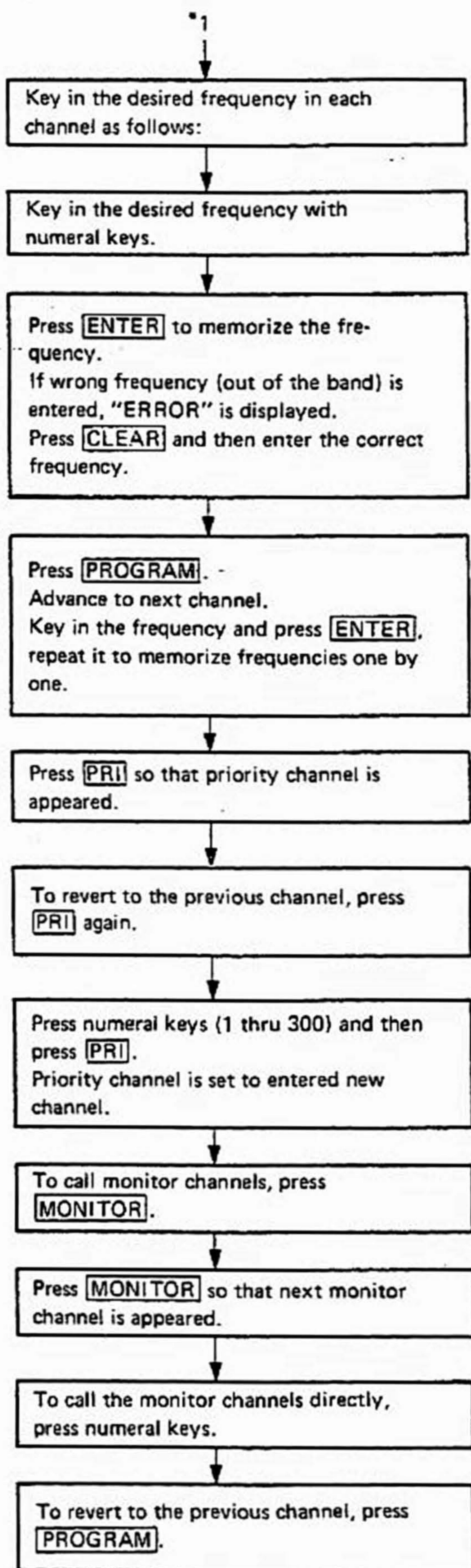

Figure B

GENERAL OPERATION OUTLINE





ALIGNMENT

ALIGNMENT AND TEST POINTS

(LINEAR PCB)

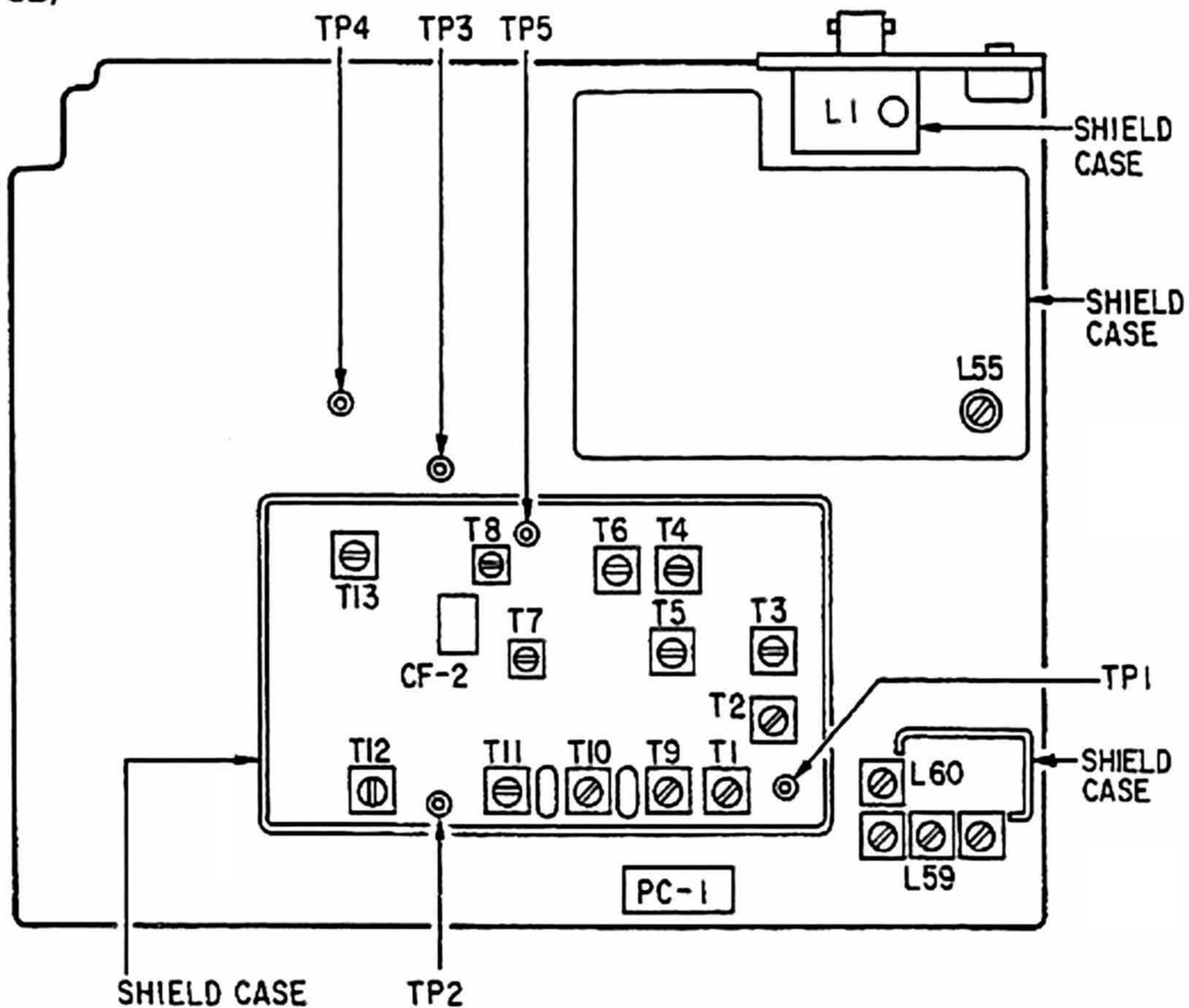

(PLL PCB)

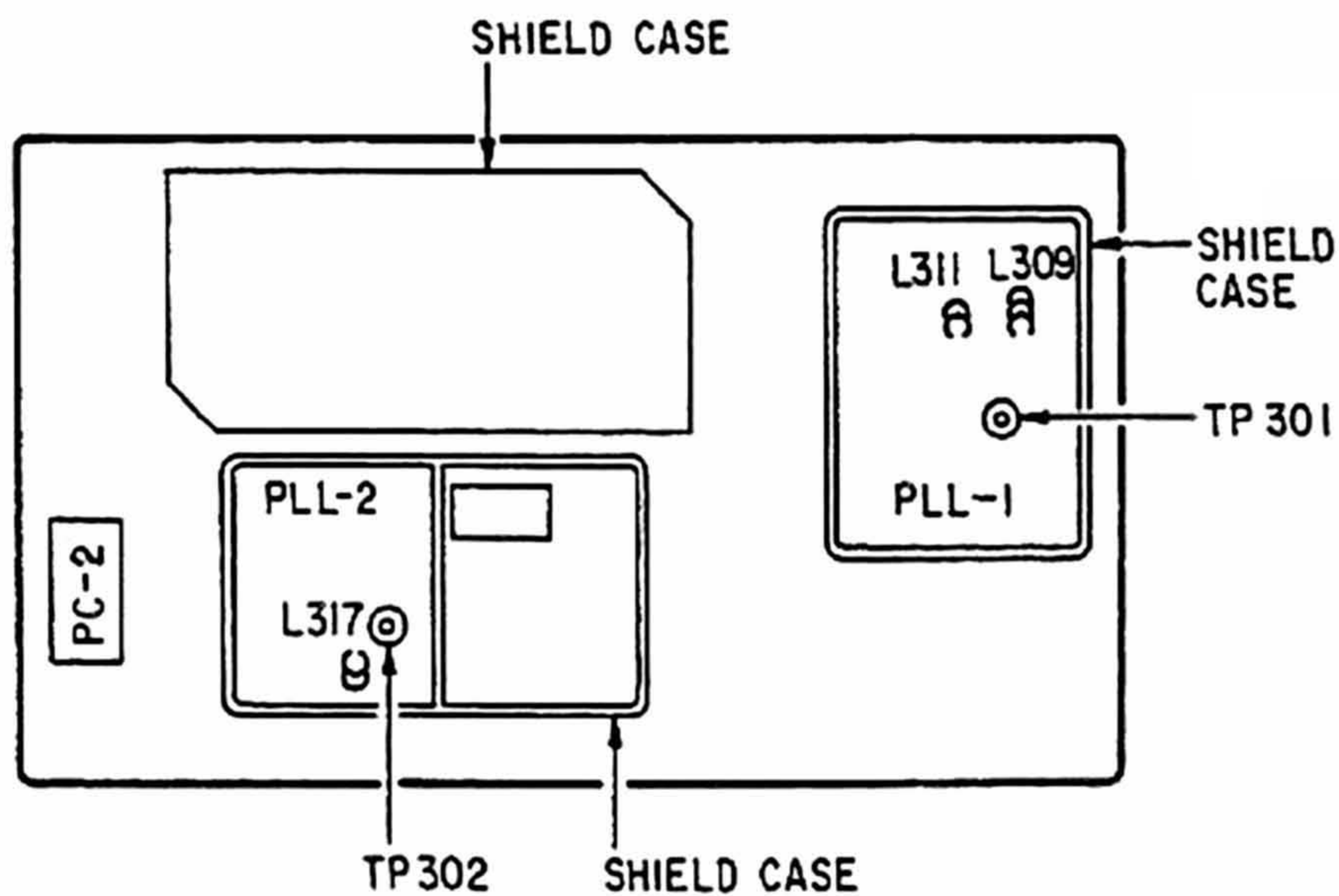

ALIGNMENT PREPARATION

Test equipment required

1. Oscilloscope
2. AC SSVM
3. DC SSVM
4. 8-ohm dummy load
5. AM, FM, Signal Generator (25 to 1300 MHz)
6. Distortion Meter

NOTE 1: *Use non-metallic tuning tools.*

The test equipment and Receiver should be warmed up at least 30 minutes before proceeding with alignment.

Input signal from the Generator should be kept as low as possible and still obtain usable output.

ALIGNMENT PROCEDURES

Step	Control Setting Channel Programming	Test Instrument Connection	Adjust	Remarks
1	OFF/VOLUME control: ON SQUELCH control: Fully counterclockwise (CCW) Channel Programming: CH1 (220.495 MHz) CH2 (520 MHz)	Connect DC SSVM to TP301 (Figure 1)	L309 L311	Alignment of VCO (PLL-1)
				1) Select Channel 1 (220.495 MHz) and adjust L309 for 20V on the DC SSVM. See Table 1. 2) Select Channel 2 (520 MHz) and adjust L311 for 20V on the DC SSVM. See Table 1.
2	OFF/VOLUME control: ON SQUELCH control: Fully CCW Channel Programming: CH3 (804.5 MHz)	Connect DC SSVM to TP302 (Figure 2)	L317	Alignment of VCO (PLL-2)
				Adjust L317 for 3V on the DC SSVM. See Table 1.

Figure 1

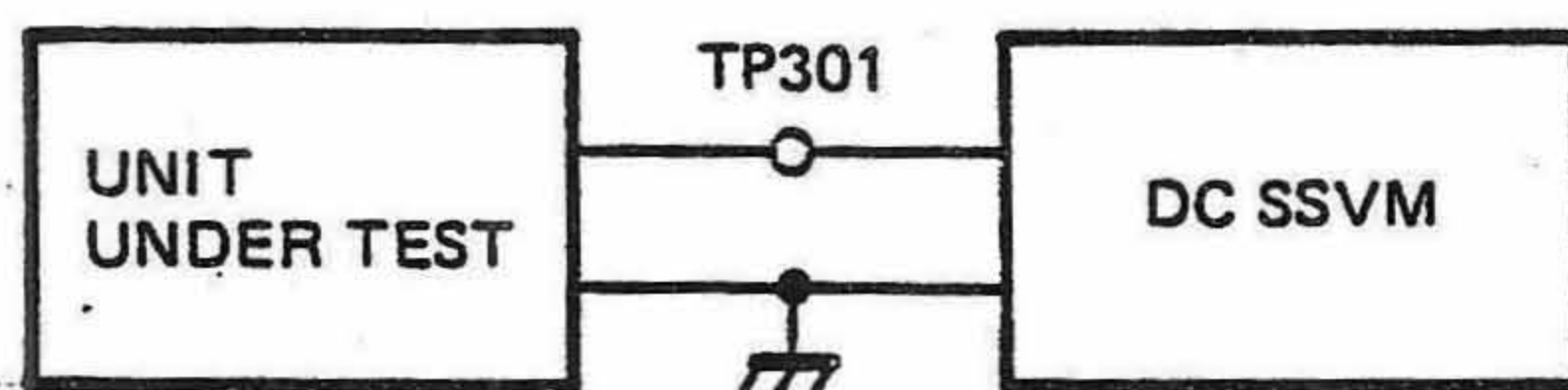

Figure 2

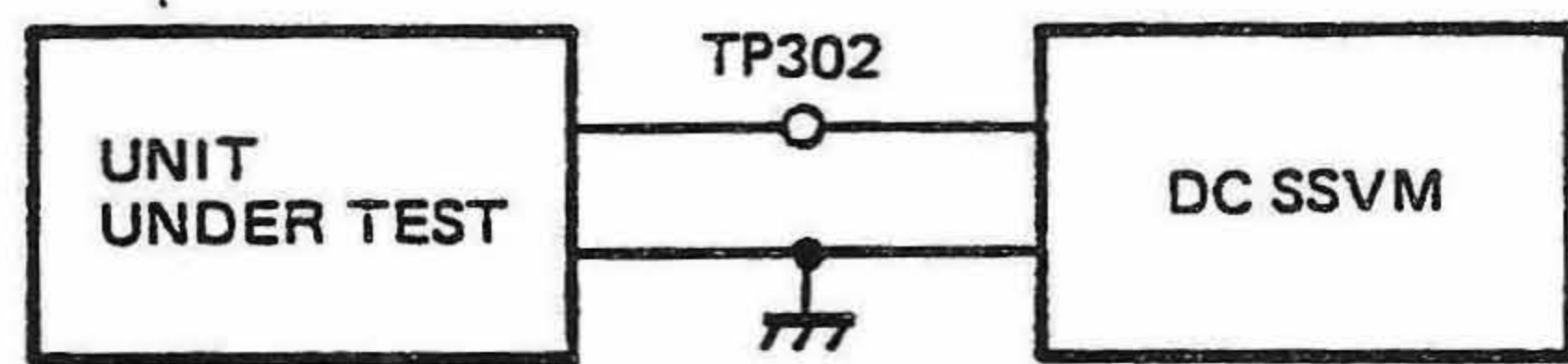
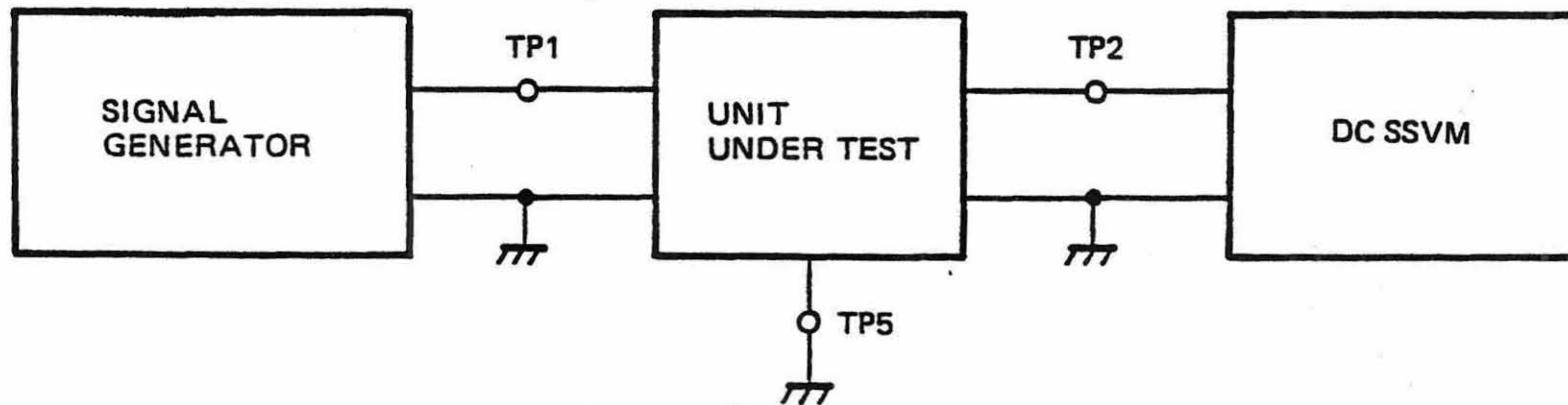

Table 1

Coil L309, L311, L317	Coil alignment (open)	Coil alignment (close)
<p>Figure 3</p> <p>Use non metallic tuning tool</p> <p>Coil</p> <p>PLL P.C.B.</p>	<p>Figure 4</p> <p>Coil</p> <p>PLL P.C.B.</p>	<p>Figure 5</p> <p>Coil</p> <p>PLL P.C.B.</p>
<p>NOTE 1: Perform coils interval alignment delicately because it affects frequency much.</p> <p>NOTE 2: Fix the coils with glue after alignment and then repeat the ALIGNMENT PROCEDURES Step 1, Step 2 after checking the fixation and temperature is normal.</p>	<p>* Open the coil as shown above by using non metallic tuning tool when a measuring voltage at TP301 or TP302 is higher than the setting voltage.</p>	<p>* Close the coil as shown above by using non metallic tuning tool when a measuring voltage at TP301 or TP302 is lower than the setting voltage.</p>

Step	Control Setting Channel Programming	Test Instrument Connection	Adjust	Remarks
3	OFF/VOLUME control: ON SQUELCH control: Fully counterclockwise Channel Programming: CH4 (250 MHz -NFM)	Connect Signal Generator to TP1, DC SSVM to TP2 and TP5 to ground. (Figure 6)	T1 T9 T10 T11 T12	Alignment of NFM/AM 2nd IF 1) Set the Signal Generator frequency to 48.5 MHz, 0.3 V output (NO MOD). 2) Adjust T1, T9, T10, T11 to maximum voltage at TP2. 3) Adjust T12 to minimum voltage at TP2, approx. 0.2V on the DC SSVM. NOTE: Perform these adjustment by using the DC SSVM which is able to measure to three decimal places because of the output voltage of TP2 is low.

Figure 6



Step	Control Setting Channel Programming	Test Instrument Connection	Adjust	Remarks
4	OFF/VOLUME control: ON SQUELCH control: Fully CCW Channel Programming: CH4 (250 MHz - NFM)	Connect Signal Generator to TP1 and DC SSVM to TP4. (Figure 7)	T13	Alignment of 455 kHz NFM Discriminator coil Set the Signal Generator frequency to 48.5 MHz, 100 μ V output (NO MOD) and adjust T13 for 3.8V (\pm 0.1) on the DC SSVM.
5	OFF/VOLUME control: ON SQUELCH control: Fully CCW Channel Programming: CH5 (98 MHz - WFM)	Connect Signal Generator to TP1 and DC SSVM to TP3. (Figure 7)	T6	Alignment of 10.7 MHz WFM Discriminator coil Set the Signal Generator frequency to 48.5 MHz, 100 μ V output (NO MOD) and adjust T6 for 3.8V (\pm 0.1) on the DC SSVM.

Figure 7

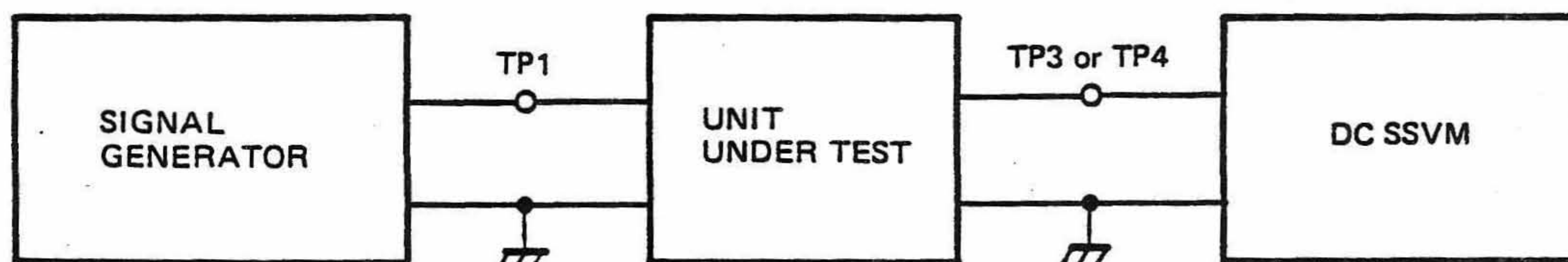

Step	Control Setting Chanel Programming	Test Instrument Connection	Adjust	Remarks
6	OFF/VOLUME control: ON SQUELCH control: Fully CCW Channel Programming: CH6 (120 MHz - AM)	Connect Signal Generator to TP1 and Oscilloscope, AC SSVM, Distortion Meter, 8Ω Load to EXT SPKR JACK. (Figure 8)	T7	Alignment of 455 kHz IF coil 1) Set the Signal Generator frequency to 48.5 MHz, AM: 60% MOD. at 1 kHz and 100 μV output 2) Adjust T7 to maximum sensitivity.
7	Same as step 6	Same as step 6	T8	Alignment of 455 kHz AM DET. coil 1) Set the Signal Generator frequency to 48.5 MHz, AM: 60% MOD. at 1 kHz and 100 μV output. 2) Adjust T8 to minimum T.H.D. point.

Figure 8

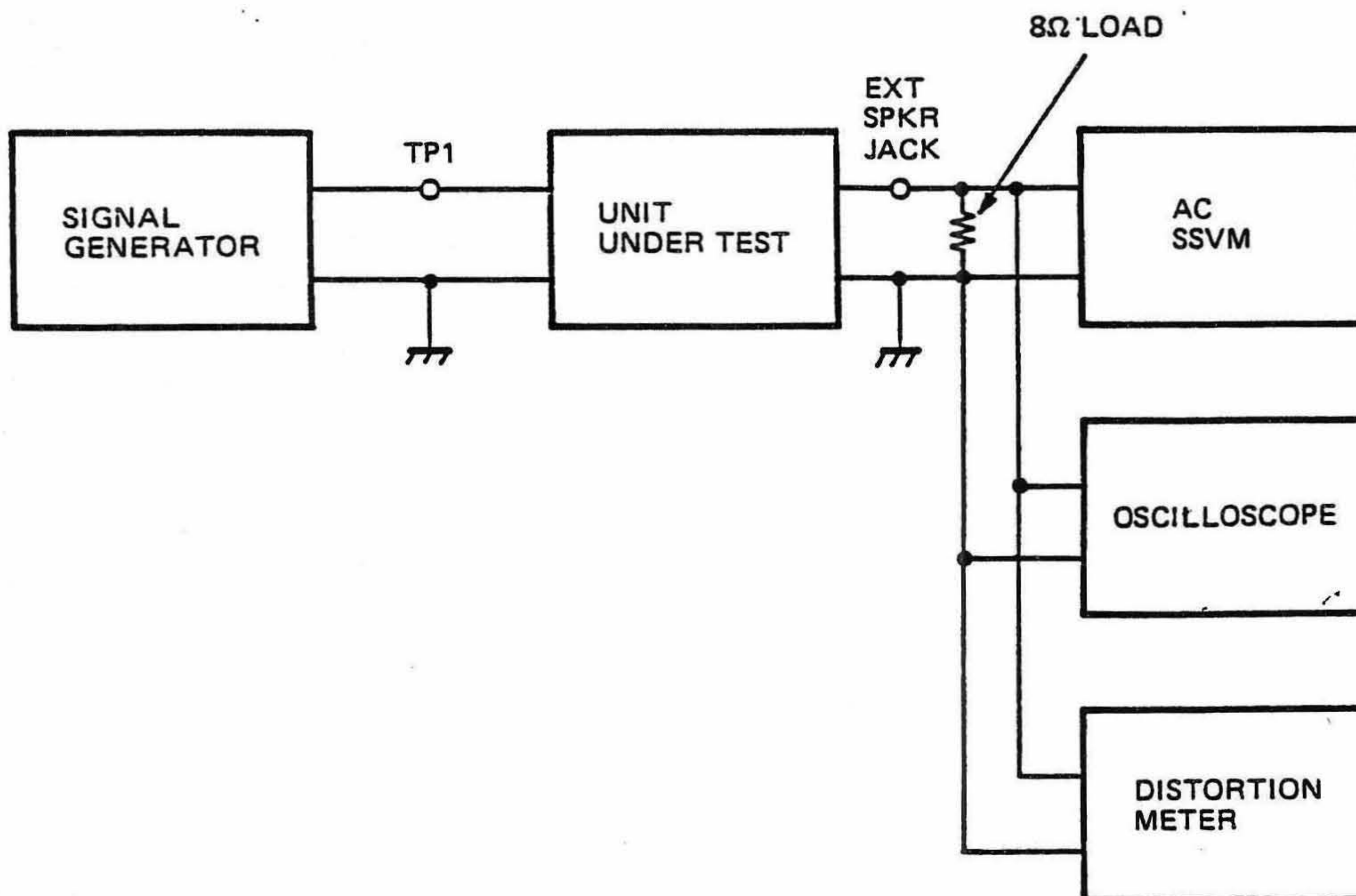

Step	Control Setting Channel Programming	Test Instrument Connection	Adjust	Remarks
8	OFF/VOLUME control: ON SQUELCH control: Fully CCW Channel Programming: CH5 (98 MHz - WFM)	Connect Signal Generator to ANT, connector and Oscilloscope, AC SSVM, 8Ω LOAD to EXT SPKR JACK. (Figure 9)	T2 T3 T4 T5	Alignment of 48.5 MHz and 10.7 MHz WFM IF coils 1) Set the Signal Generator frequency to 98 MHz FM: 22.5 kHz DEV. at 1 kHz MOD, output approx. 2 μV. 2) Adjust T2, T3 to maximum sensitivity. NOTE: Alignment of T4, T5 are not necessary. When those core are turned, adjust cores so that those tops of cores become as high as those coil case.

Figure 9

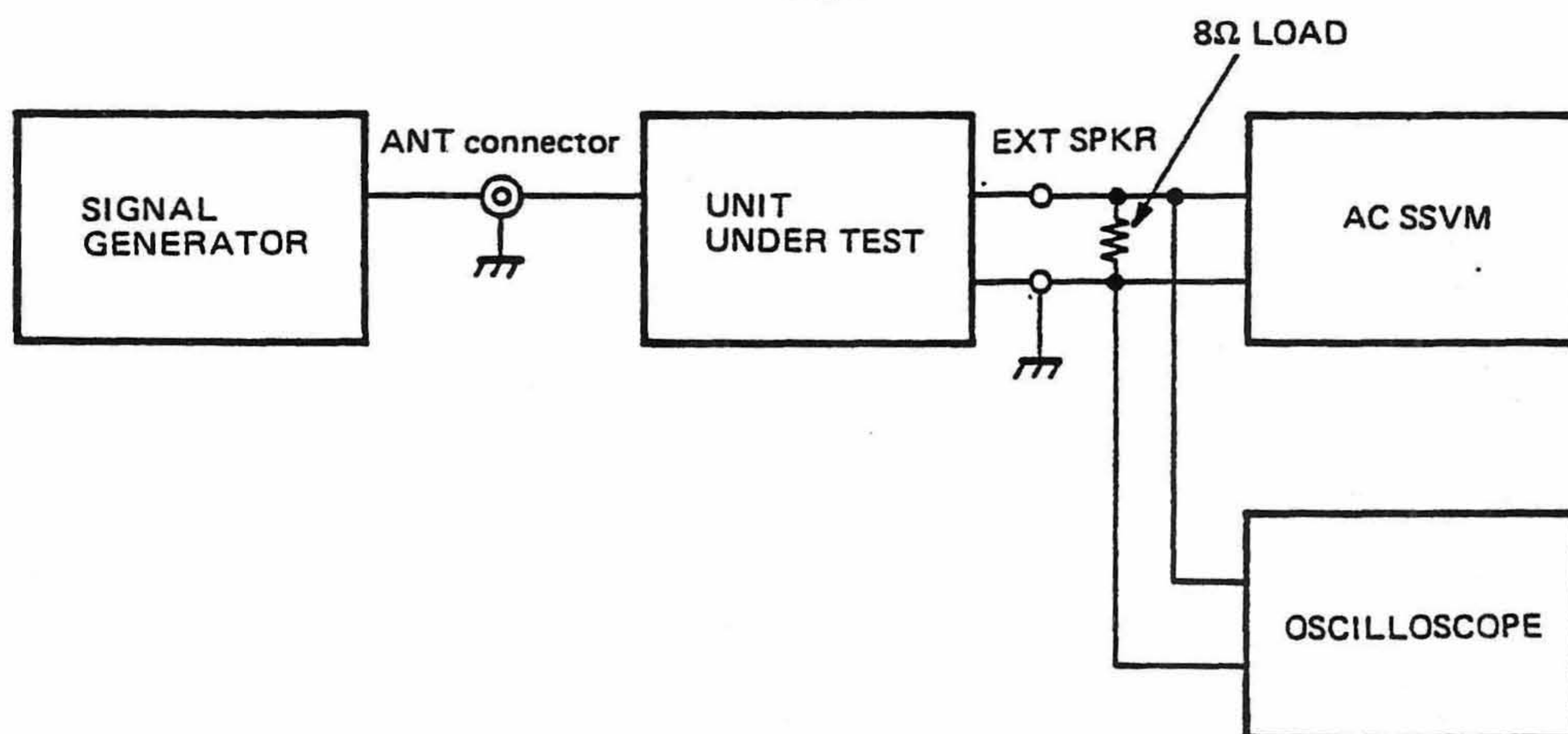

Step	Control Setting Channel Programming	Test Instrument Connection	Adjust	Remarks
9	OFF/VOLUME control: ON SQUELCH control: Fully CCW Channel Programming: CH7 (300.495 MHz - NFM)	Same as step 8	L1 L55	Alignment of IF TRAP coils 1) Set the Signal Generator frequency to 609.505 MHz FM: 3 kHz DEV. 1 kHz MOD. Output, approx. 3 mV 2) Adjust L1 and L55 to minimum sensitivity.
10	OFF/VOLUME control: ON SQUELCH control: Fully CCW Channel Programming: CH8 (240.495 MHz - NFM)	Same as step 8	L60	Alignment of 512 MHz TRAP coil 1) Set the Signal Generator frequency to 337.495 MHz FM: 3 kHz DEV. 1 kHz MOD, Output, approx. 3 mV 2) Adjust L60 to minimum sensitivity.

NOTE: Alignment of L59 (GR-H763, B.P.F. coil)
 Do not adjust this coil because of L59 is already adjusted at Factory.
 When turn the coil core, perform the alignment as below (step 11).
 B.P.F. characteristic is Figure 10.

Step	Control Setting Channel Programming	Test Instrument Connection	Adjust	Remarks
11	OFF/VOLUME control: ON SQUELCH control: Fully CCW Channel Programming: CH9 (800.495 MHz) CH10 (800.500 MHz)	Same as step 8 (Figure 9)	L59	Alignment 1st IF (611.5 to 607.505 MHz) B.P.F. coil 1) Select channel 7 (800.495 MHz) and set the Signal Generator frequency to 800.495 MHz, FM: 3 kHz DEV. at 1 kHz and 1 μ V output. 2) Adjust L59 to maximum sensitivity. 3) Select channel 8 (800.500 MHz) and set the Signal Generator frequency to 800.500 MHz, FM: 3 kHz DEV. at 1 kHz and 1 μ V output. 4) Adjust L59 to maximum sensitivity. NOTE: Align the balance of CH9, CH10 sensitivity to become same.

Figure 10

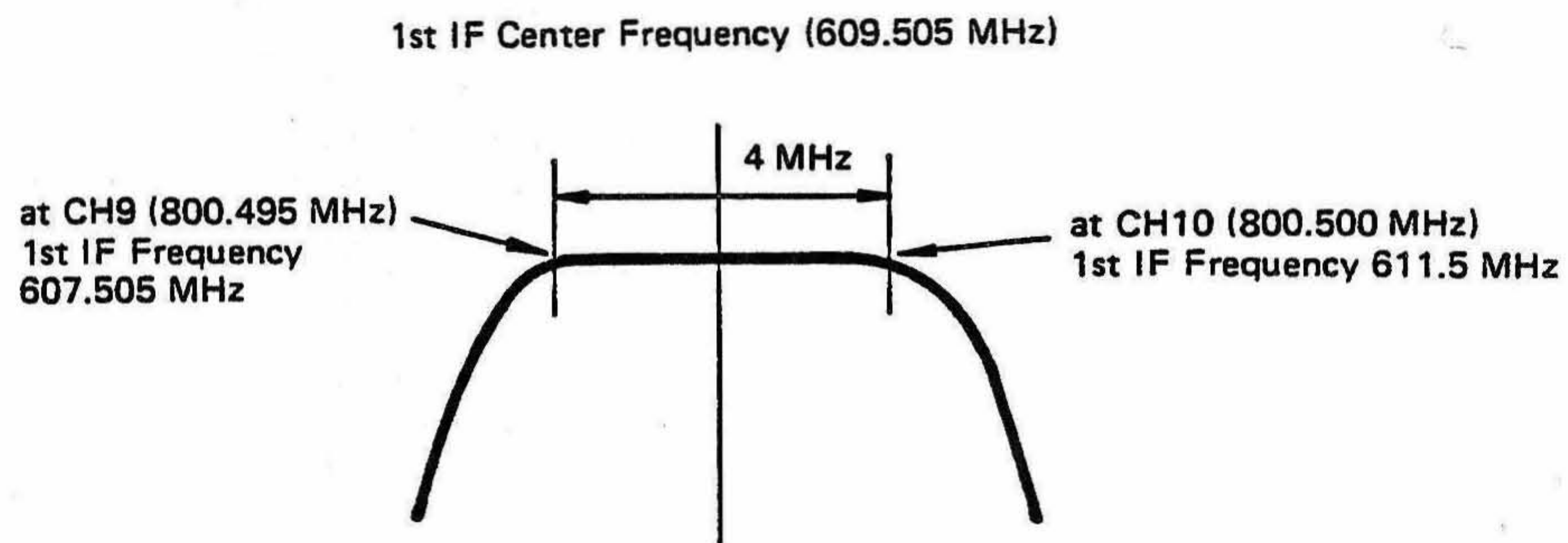

ZEROMATIC FUNCTION TEST PROCEDURE

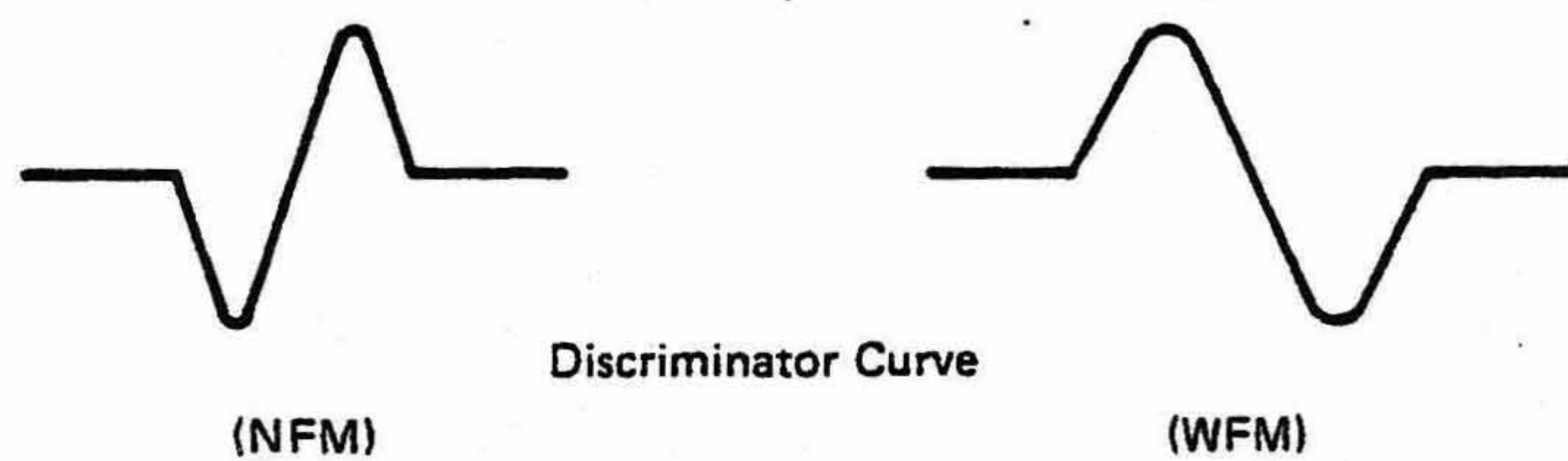
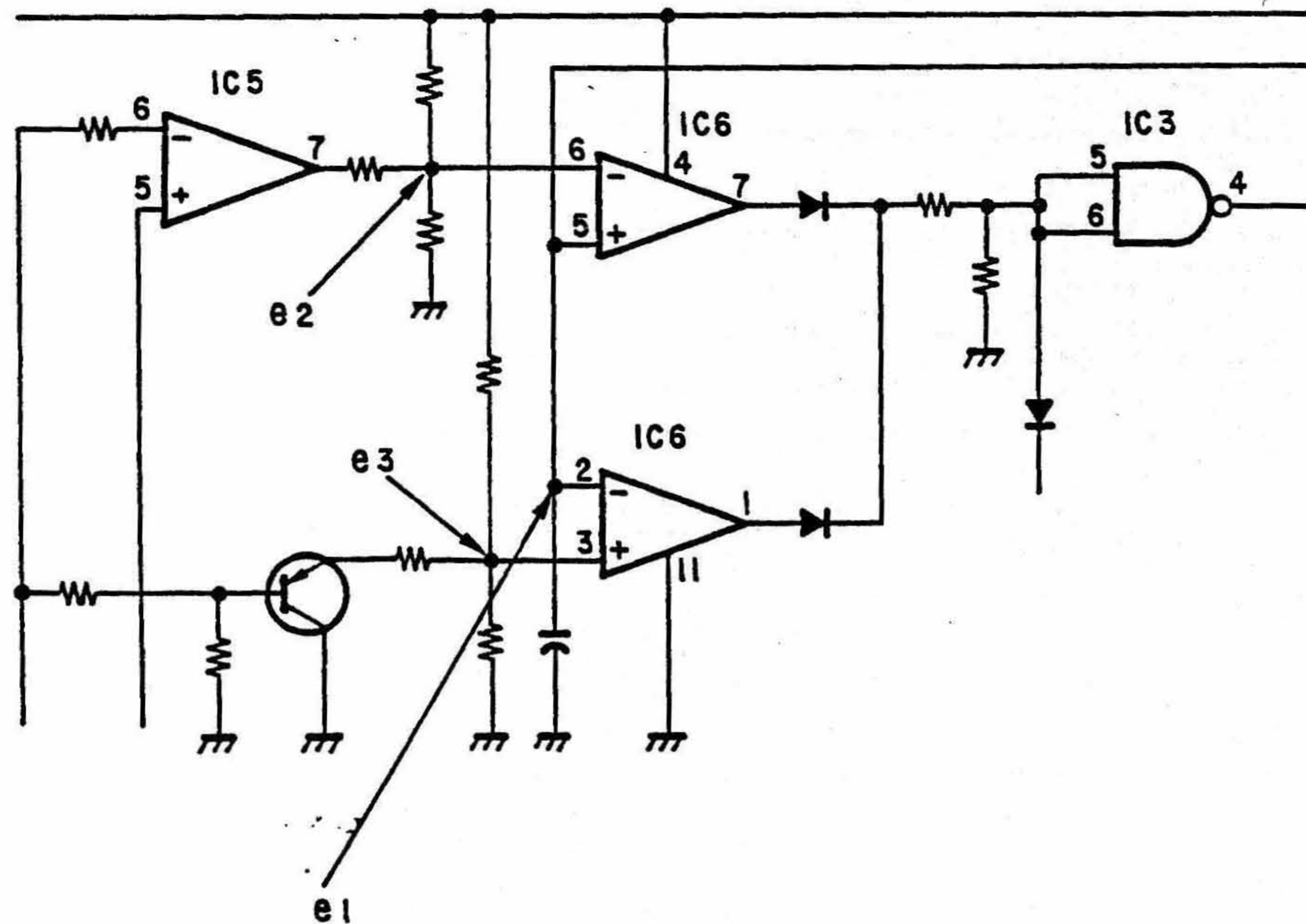

Discriminator Curve

(NFM)

(WFM)

(Zeromatic functions when OUTPUT is in "H" level.)

	$0 < e1 < e3$	$e3 < e1 < e2$	$e2 < e1 < VCC$
OUTPUT (IC3 Pin No. 4)	L	H	L

(NFM MOD.)

To adjust e1 voltage, receive signal in Manual mode, and set T13 to obtain 3.8 V (± 0.1 V) at TP4. It is convenient to use the National Weather Service signal for the adjustment.

(WFM MOD.)

To adjust e1 voltage, receive signal in Manual mode and set T6 to obtain 3.8 V (± 0.1 V) at TP3. It is convenient to use the FM. TV. sound signal for the adjustment.

KEYS ACCESS PULSE OUTPUT (IC-503)

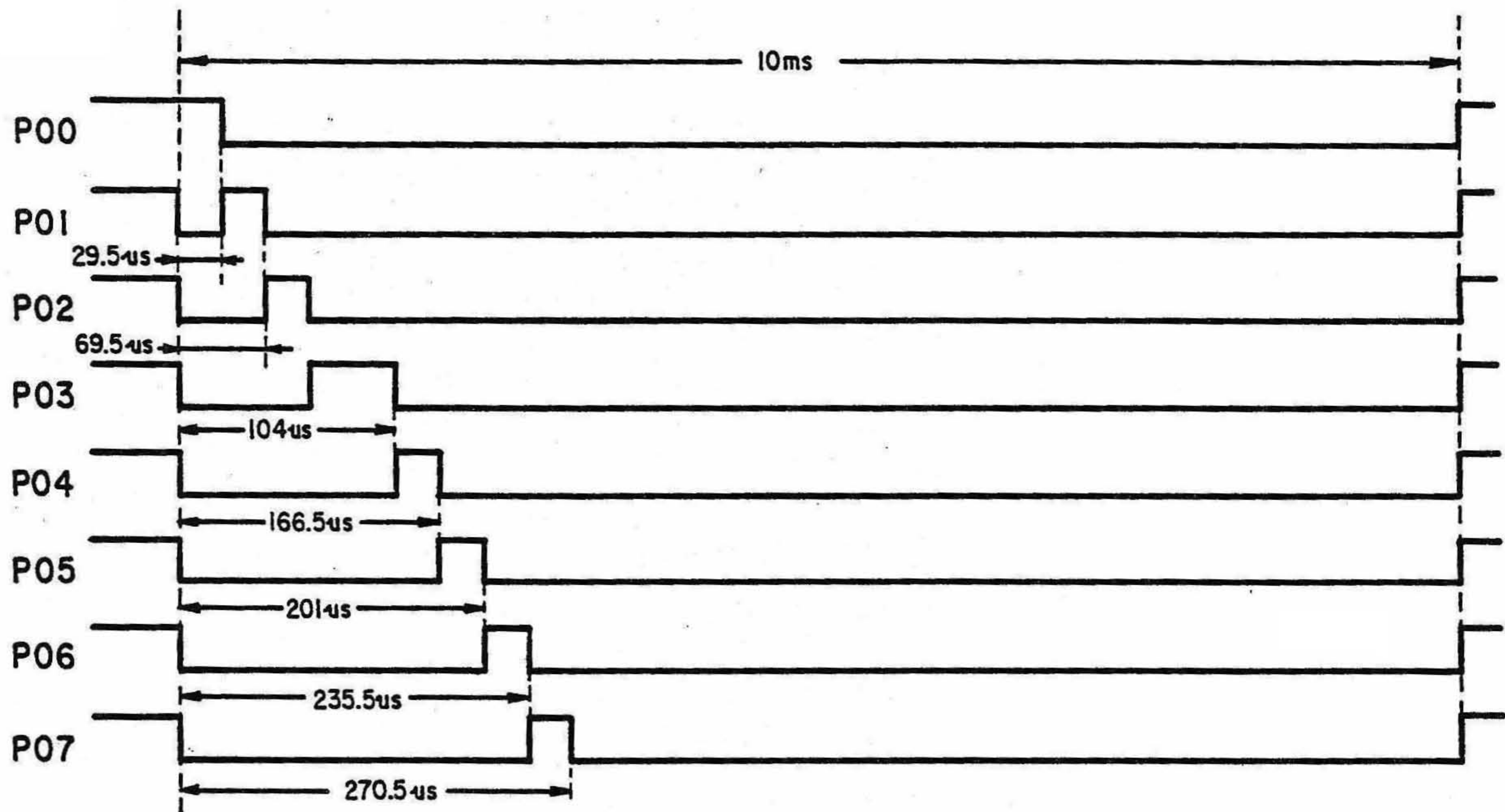

NOTE: Use a signal at P01 of IC-503 as trigger, and then observe the keys access pulse when **PROGRAM** key is pressed.

DATA WAVEFORM (IC-503)

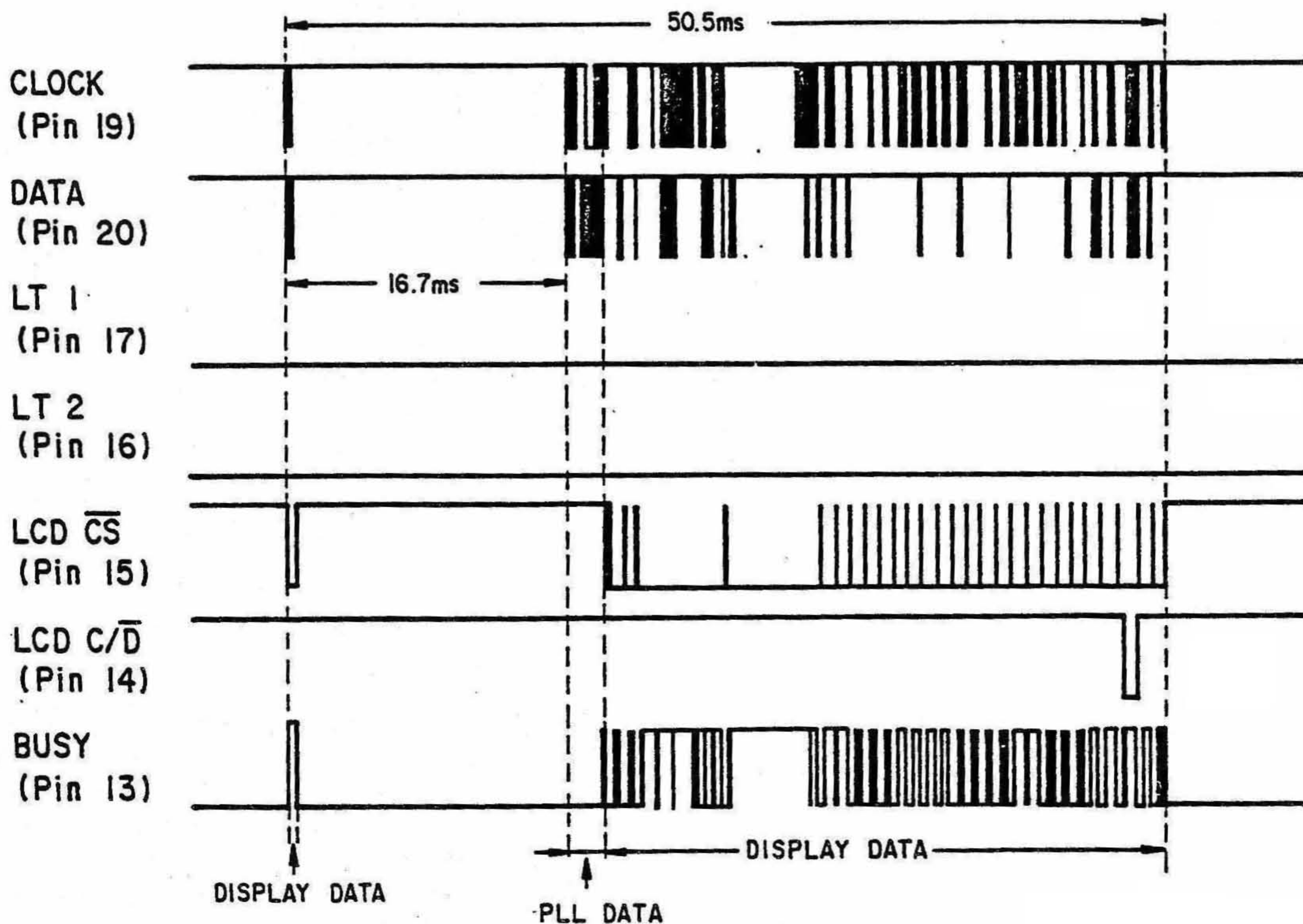

PLL DATA WAVEFORM

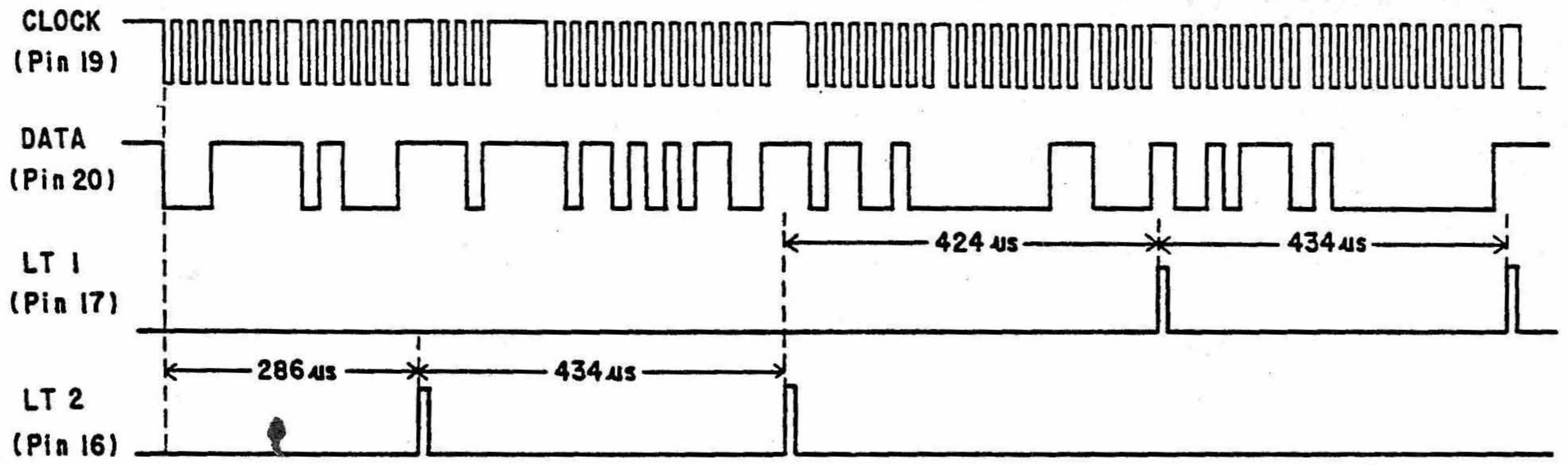

NOTE: Data in Program mode when 150.000 MHz entered.

RECEPTION CHECK

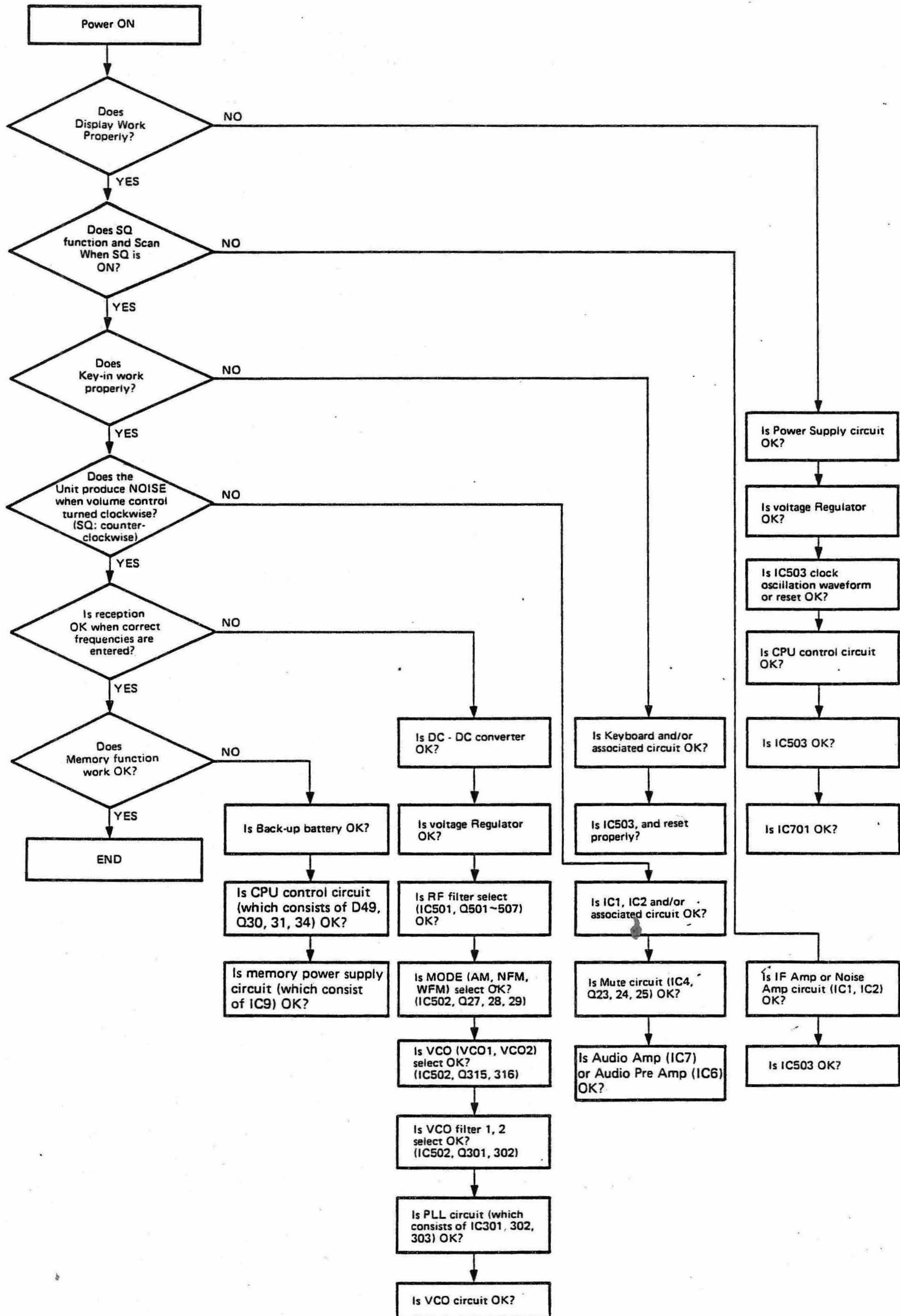

MEMORY CHECK

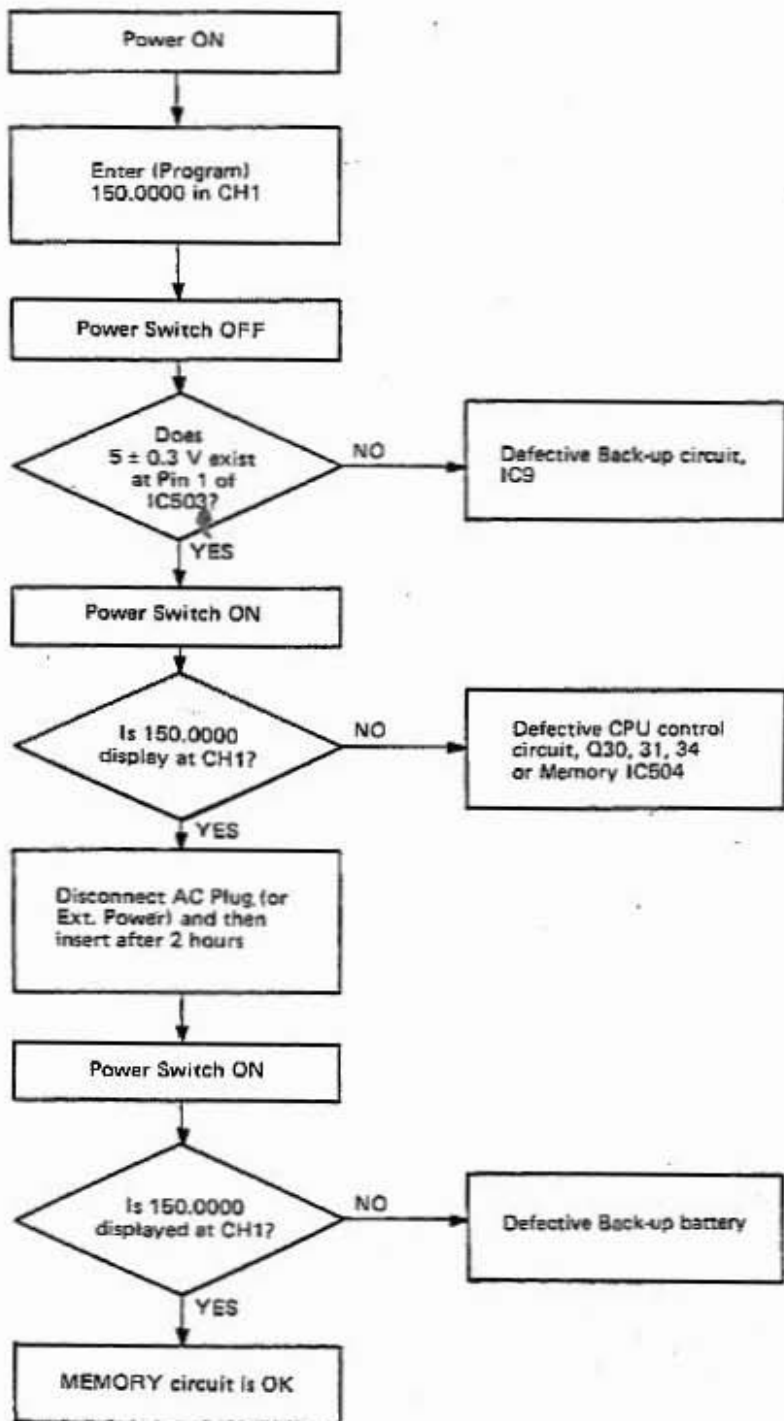

TROUBLESHOOTING

Symptom	Cause/Remedy
1) Does not display and no sound when POWER is ON. Volume control: MAX. Squelch control: CCW (counter-clockwise)	<ol style="list-style-type: none"> 1) Defective AC Line Cord: Replace. 2) Defective Power transformer T801: Replace. 3) Defective Off/Volume control VR801: Replace. 4) Defective Rectifier D55: Replace. 5) Defective voltage regulator circuit: Replace the defective components. 6) Defective CPU control circuit consists of Q30, Q31, Q34, D49: Replace the defective components.
2) Displays but no sound.	<ol style="list-style-type: none"> 1) Defective speaker or headphone jack: Replace. 2) Defective Audio Amp. circuit consists of IC7: Replace the defective components. 3) Defective IF Amp. circuit consists of IC1, IC2: Replace the defective components. 4) Defective Squelch control circuit consists of IC3, IC4: Replace the defective components. 5) Defective AF Pre Amp. circuit consists of IC6: Replace the defective components. 6) Defective Audio Mute Switching circuit consists of IC3, IC4 and Q23, Q24, Q25: Replace the defective components. 7) Defective Switching circuit consists of IC4, D34, D38, D39 and D40: Replace the defective components.
3) Sounds but no display	<ol style="list-style-type: none"> 1) IC503 is running "wild": Press RESTART Switch. 2) Defective initiate control circuit: Replace the defective components. 3) Defective voltage regulator circuit consists of IC9: Replace the defective components. 4) Defective LCD: Replace. 5) Defective CPU circuit consists of IC503: Replace the defective components. 6) Defective LCD Controller circuit consists of IC701: Replace the defective components.
4) Backlight does not light	<ol style="list-style-type: none"> 1) Defective EL Driver circuit consists of T701, Q701: Replace the defective components. 2) Defective EL: Replace.
5) Does not squelch and does not scan.	<ol style="list-style-type: none"> 1) Defective Switching circuit consists of IC3: Replace IC3. 2) Defective IC2 squelch control output terminal: Replace IC2. 3) Defective voltage regulator circuit consists of Q32, D50: Replace the defective components.
6) Squelch operates but does not scan.	<ol style="list-style-type: none"> 1) IC503 is running "wild": Press RESTART Switch. 2) Defective CPU circuits: Replace the defective components.
7) Operates in MANUAL but does not operate in SCAN.	Squelch control is not adjusted correctly: Adjust Squelch (VR802).
8) Displays but PROGRAM does not operate.	Defective Keyboard or connector and/or associated circuit: Replace the defective components.

Symptom	Cause/Remedy
9) No sound in AM mode but NFM, WFM operate.	1) Defective IC502 or IC503: Replace. 2) Defective Switching circuit consists of Q29, D40, D45: Replace the defective components. 3) Defective ANL, AF Pre Amp. circuit consists of D32, Q22: Replace the defective components. 4) Defective AM IF DET. circuit consists of Q16, Q17, D31: Replace the defective components.
10) No sound in NFM mode but AM, WFM operate.	1) Defective IC502 or IC503: Replace. 2) Defective Switching circuit consists of Q28, D46: Replace the defective components.
11) No sound in AM and NFM MODE but WFM operate.	1) Defective IC2: Replace.
12) No sound in WFM mode but AM, NFM operate.	1) Defective IC502, 503 or IC1: Replace. 2) Defective Switching circuit consists of Q27, D47: Replace the defective components.
13) Low sensitivity between 25.0000 to 39.9950 MHz.	1) Defective DECODER SWITCHING circuit consists of IC501, Q501: Replace the defective components. 2) Defective Bandpass filter (B.P.F): Replace the defective components.
14) Low sensitivity between 40.0000 to 67.9950 MHz.	1) Defective DECODER SWITCHING circuit consists of IC501, Q502: Replace the defective components. 2) Defective B.P.F: Replace the defective components.
15) Low sensitivity between 68.0000 to 107.9950 MHz.	1) Defective DECODER SWITCHING circuit consists of IC501, Q503: Replace the defective components. 2) Defective B.P.F: Replace the defective components.
16) Low sensitivity between 108.0000 to 173.9950 MHz.	1) Defective DECODER SWITCHING circuit consists of IC501, Q504: Replace the defective components. 2) Defective B.P.F: Replace the defective components.
17) Low sensitivity between 174.0000 to 279.9950 MHz.	1) Defective DECODER SWITCHING circuit consists of IC501, Q505: Replace the defective components. 2) Defective B.P.F: Replace the defective components.
18) Low sensitivity between 280.0000 to 520.0000 MHz.	1) Defective DECODER SWITCHING circuit consists of IC501, Q506: Replace the defective components. 2) Defective B.P.F: Replace the defective components.
19) Low sensitivity between 760.0000 to 1300.0000 MHz.	1) Defective DECODER SWITCHING circuit consists of IC501, Q507: Replace the defective components. 2) Defective B.P.F: Replace the defective components.
20) Does not operate between 25.0000 to 220.4950 MHz or 760.0000 to 1052.4950 MHz.	Defective IC503 port P10, IC502, Q315 and/or VCO-1 circuit: Replace the defective components.

Symptom	Cause/Remedy
21) Does not operate between 220.5000 to 520.0000 MHz or 1052.5000 to 1300.0000 MHz.	Defective IC503 port P11, IC502, Q316 and/or VCO-2 circuit: Replace the defective components.
22) Low sensitivity between 25.0000 to 520.0000 MHz.	Defective IC503 port P66, IC502, Q301 and/or VCO filter-1 circuit: Replace the defective components.
23) Low sensitivity between 760.0000 to 1300.0000 MHz.	Defective IC503 port P67, IC502, Q302 and/or VCO filter-2 circuit: Replace the defective components.
24) All band do not operate but display is OK.	1) Defective PLL circuit IC301, IC302, IC303, IC304 and/or associated circuit: Replace the defective components. 2) Defective IC305, IC306 and/or associated circuit: Replace the defective components.
25) Searches but does not halt on the correct frequency.	1) Defective IC6: Replace. 2) Discriminator Coil T13 (AM and NFM mode or T6 (WFM mode) is out of adjustment: TP4 shall have approx. 3.8 V in normal receiving AM and NFM mode. TP3 shall have approx. 3.8 V in normal receiving WFM mode.

P.C. BOARDS (TOP & BOTTOM VIEWS)

LINEAR P.C. BOARD (TOP VIEW)

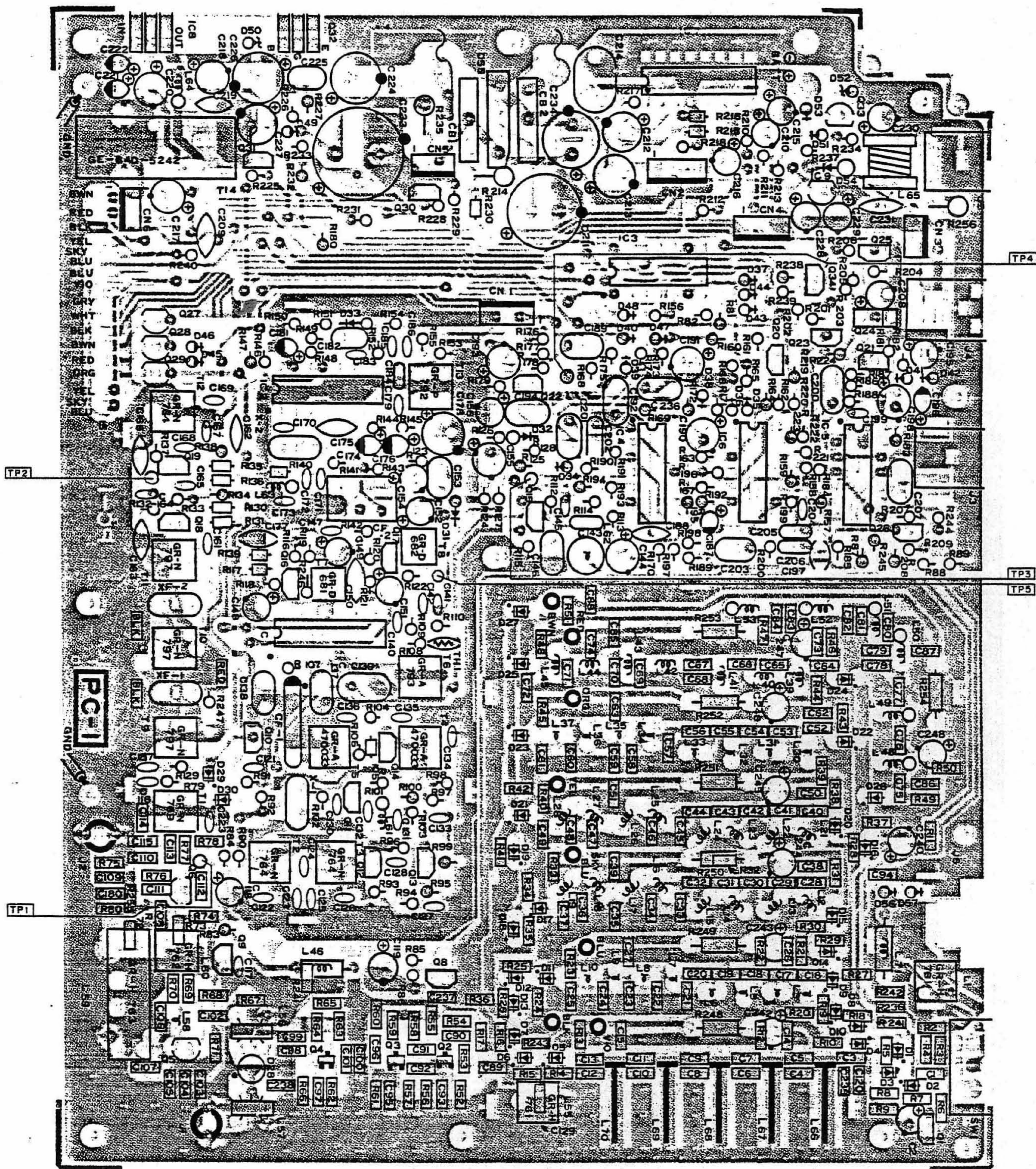

LINEAR P.C. BOARD (BOTTOM VIEW)

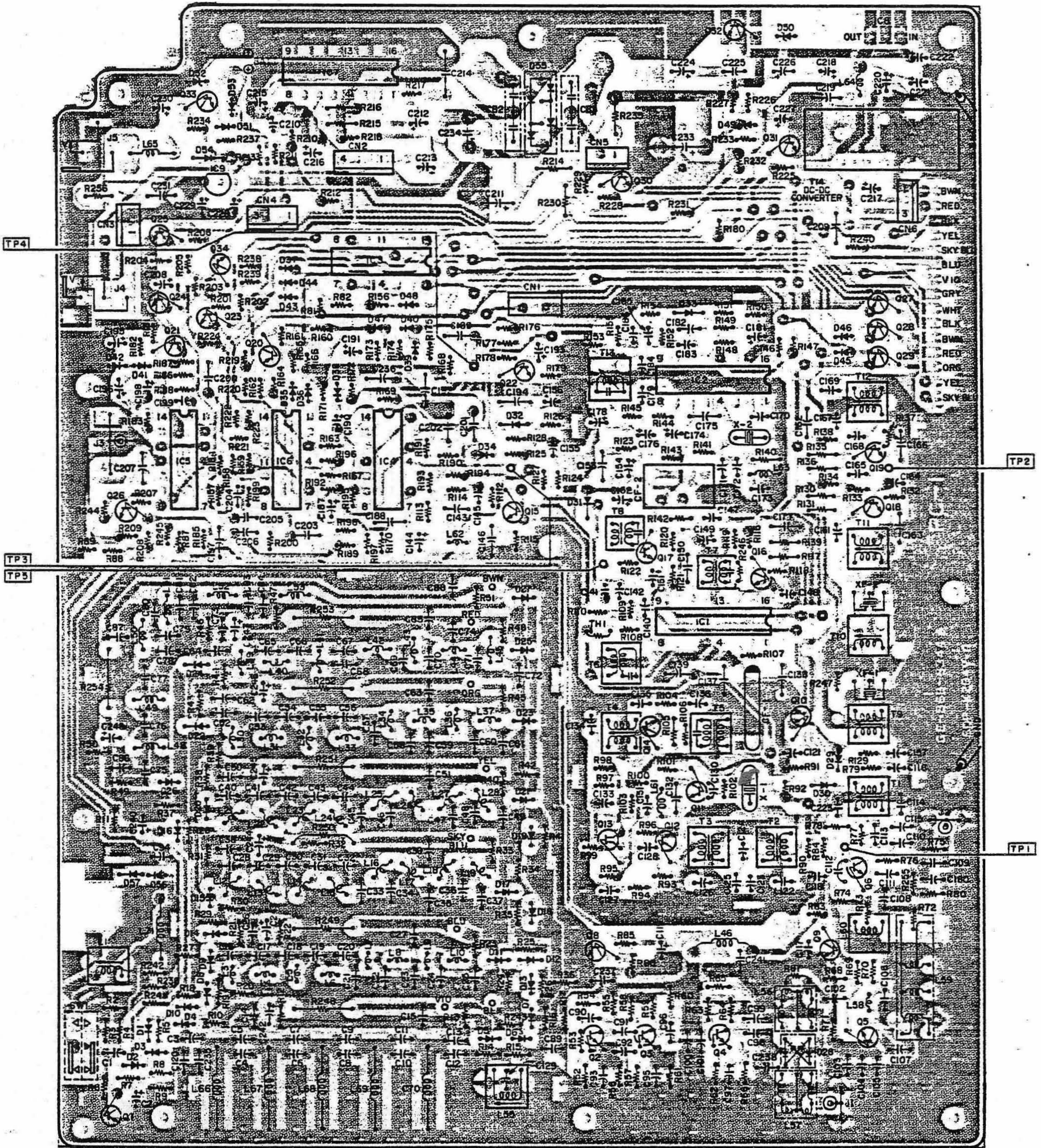

CPU P.C. BOARD (TOP VIEW)

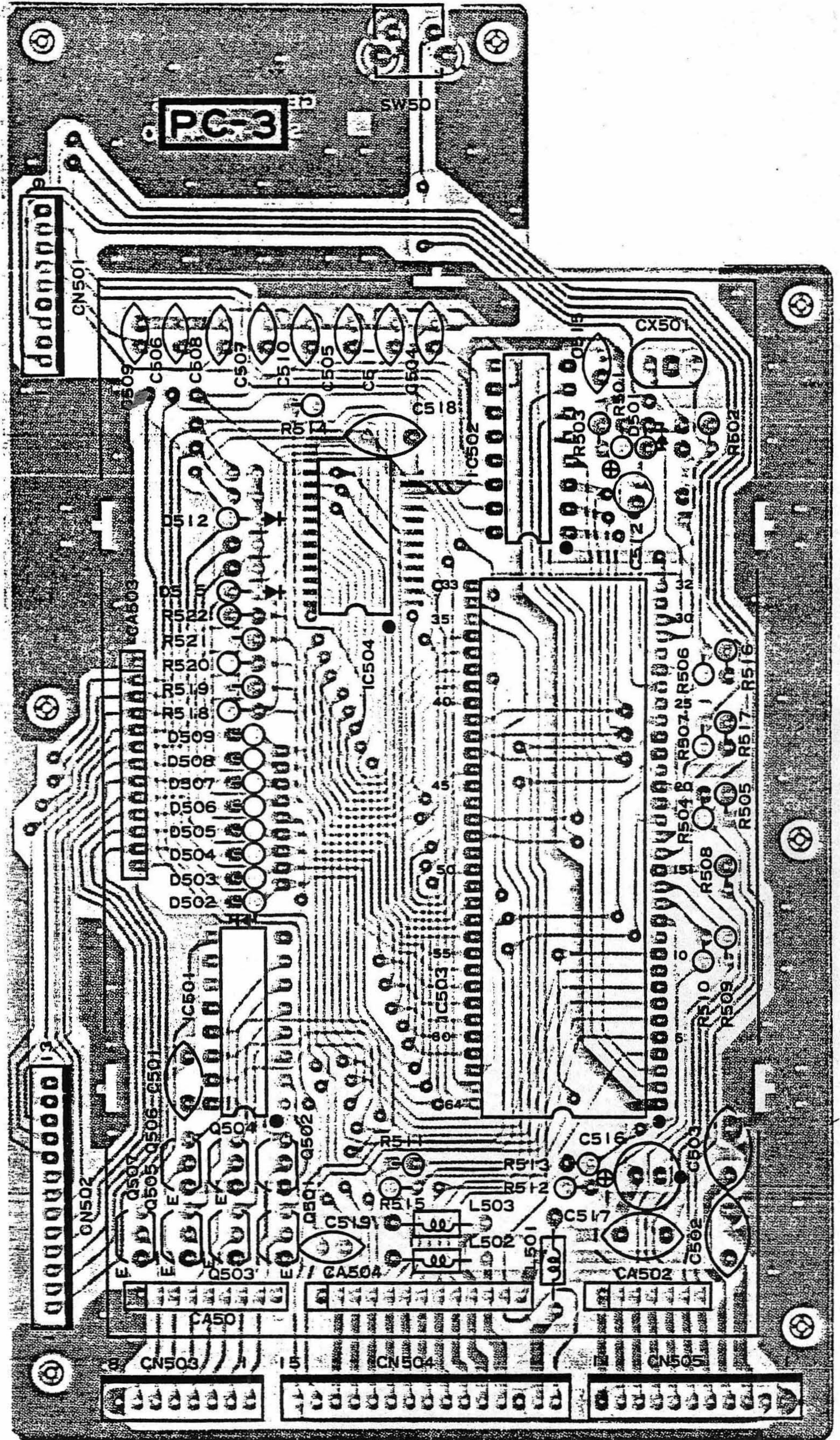

CPU P.C. BOARD (BOTTOM VIEW)

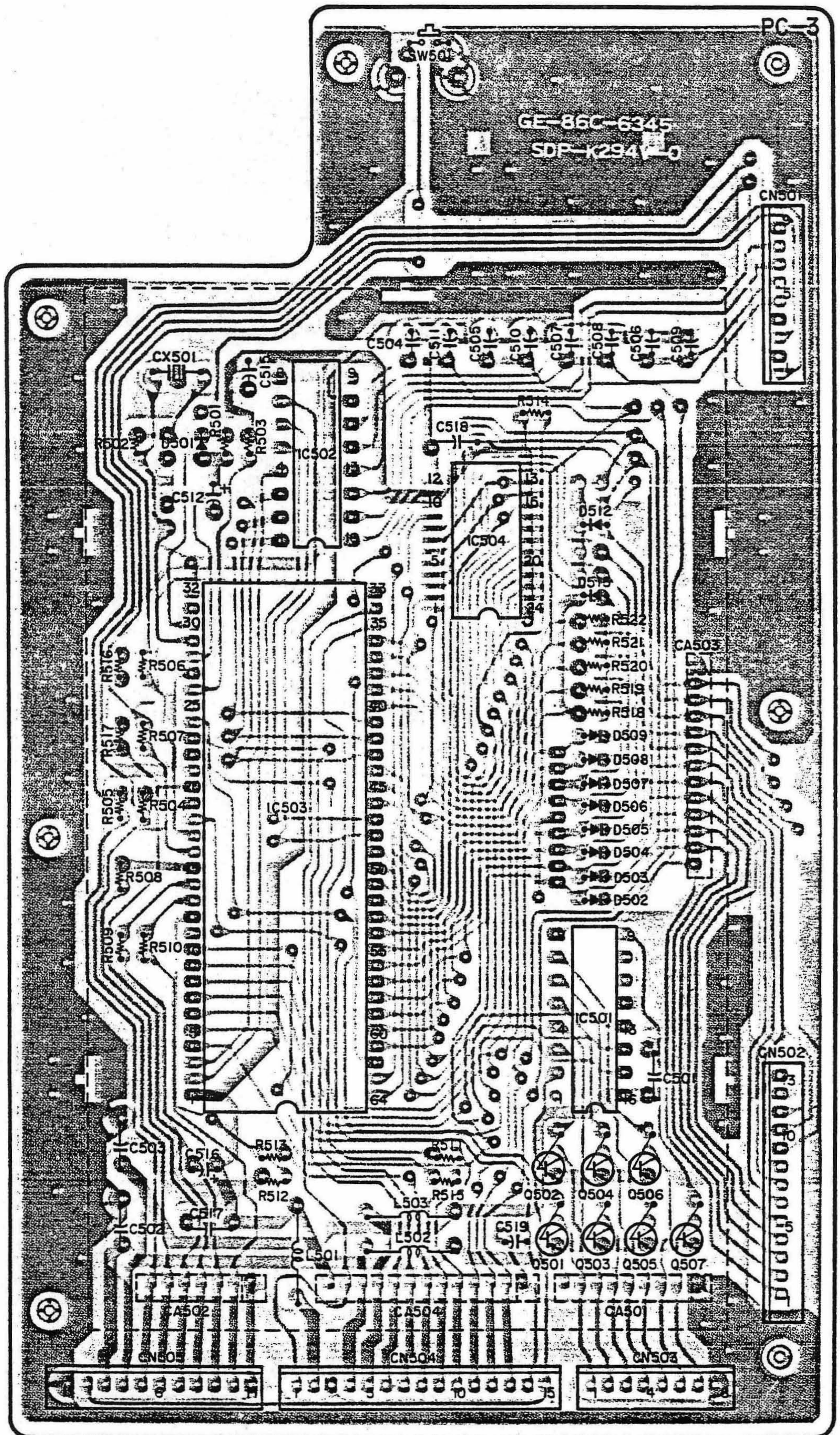

PLL P.C. BOARD (TOP VIEW)

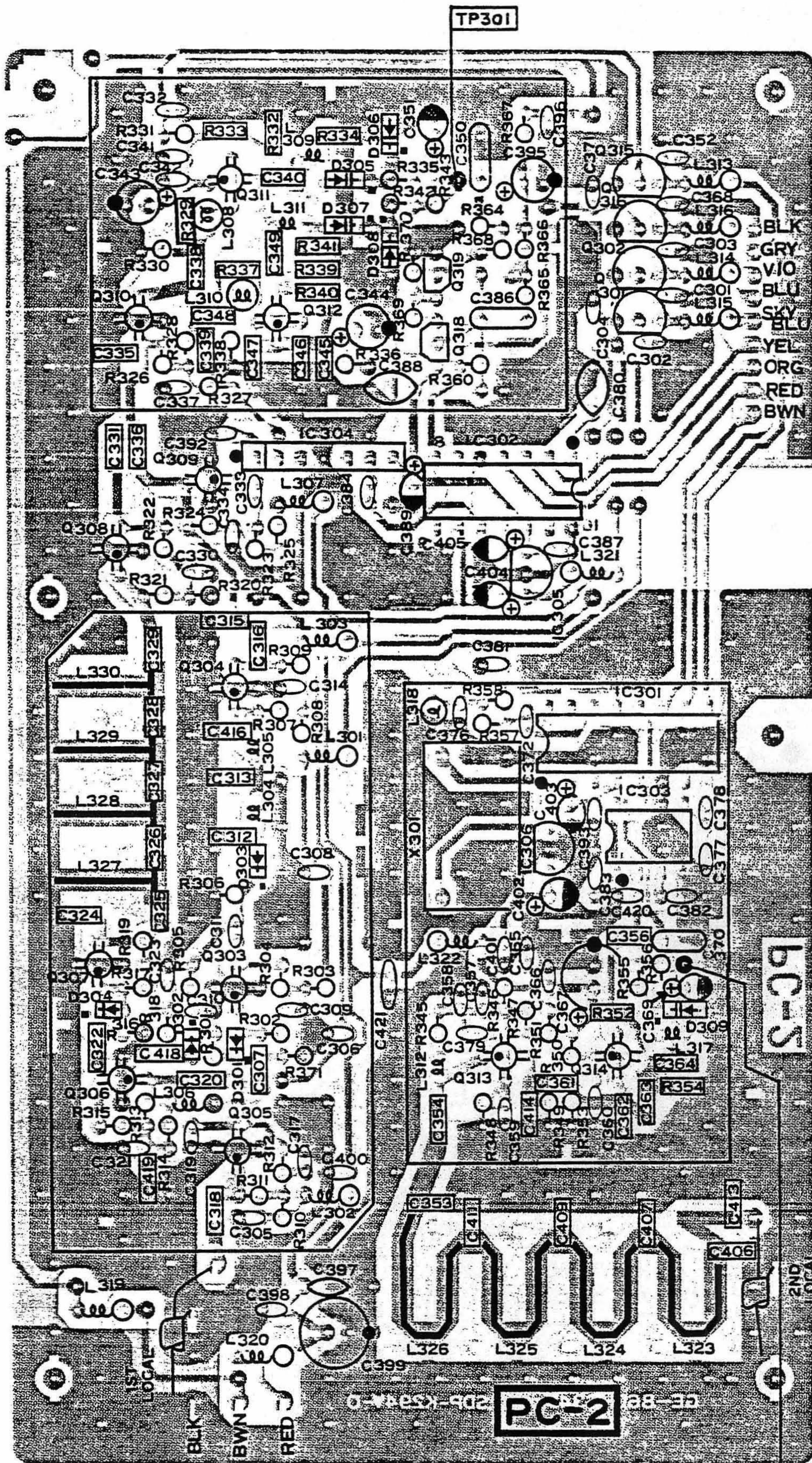

PLL P.C. BOARD (BOTTOM VIEW)

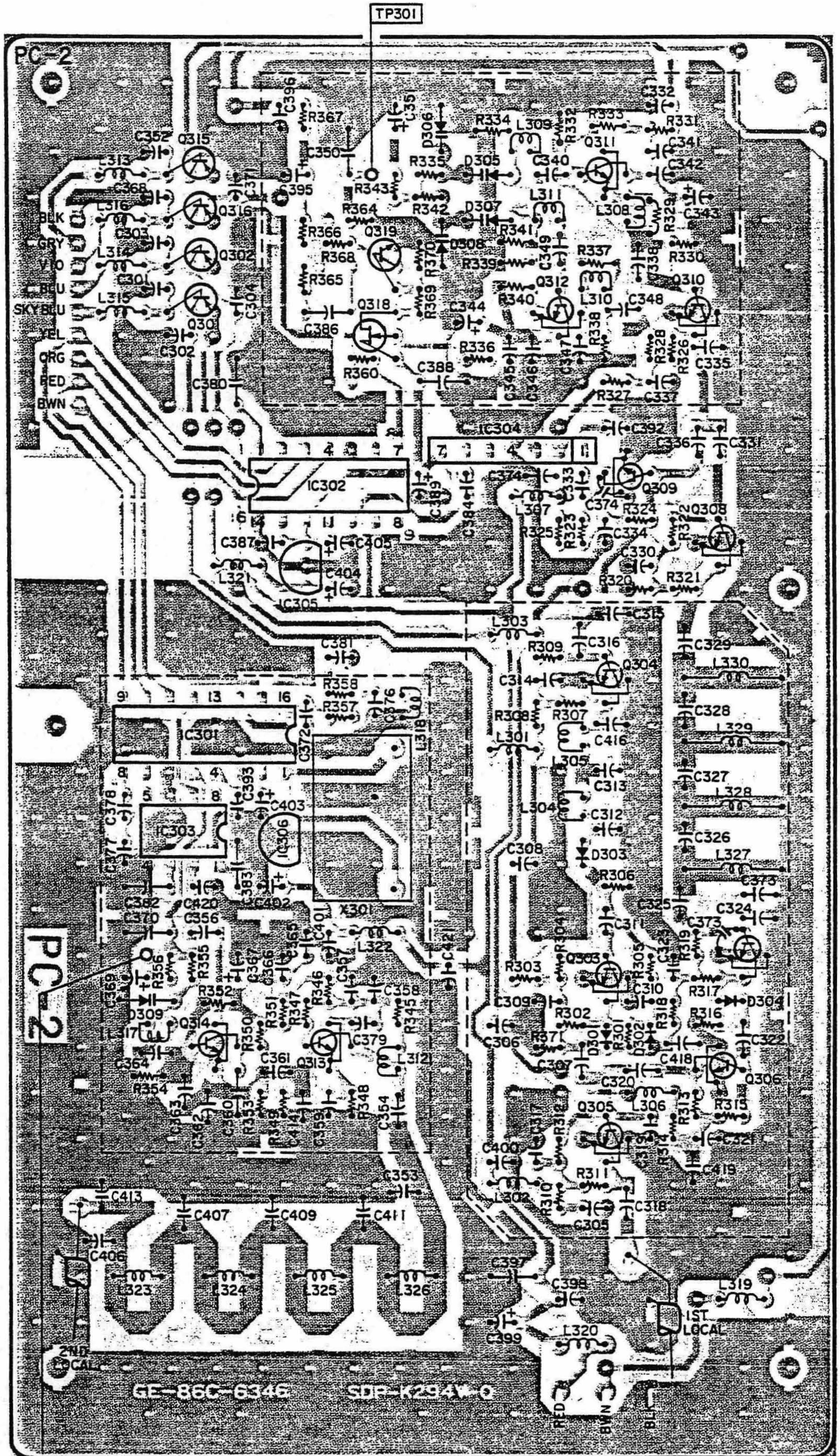

TP302

WIRING DIAGRAM

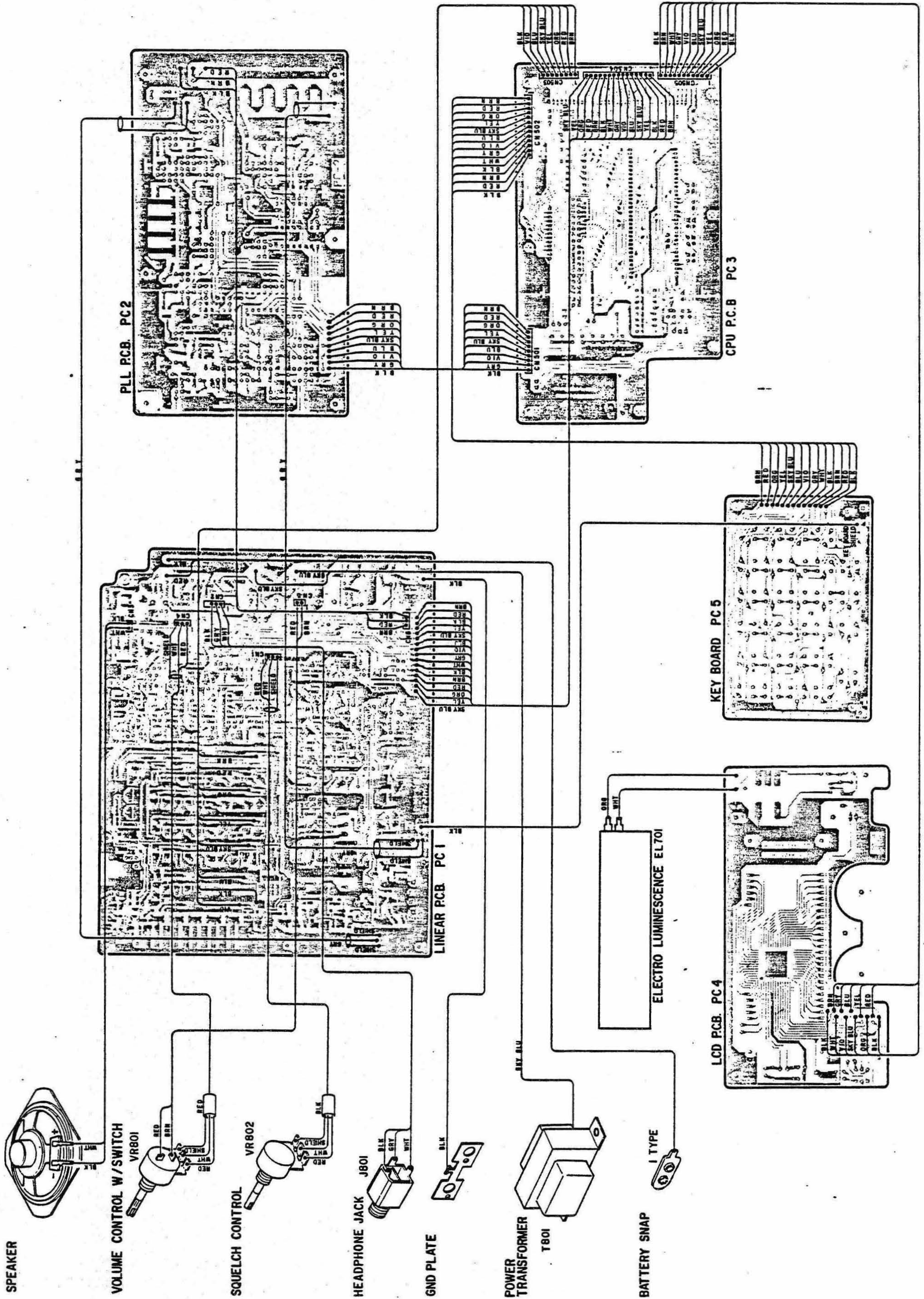

ELECTRICAL PARTS LIST

PRODUCT SAFETY NOTE: Products marked with a Δ have special characteristics important to safety. Before replacing any of these components, read carefully the product safety notice of this service manual. Don't degrade the safety of the product through improper servicing.

CAPACITORS						
Ref. No.	Description				RS Part Number	MFR's Part Number
C1	Chip	0.001 μ F	50WV	\pm 10%	CD-102KJBC	T1C3K31P1HC102K
C2	Electrolytic	10 μ F	16WV	\pm 20%	CC-106MDCA	16MV100SS
C3	Chip	5pF	50WV	\pm 0.5pF	CD-050CJBC	C2C31P1HCG050D
C4	Chip	0.5pF	50WV	\pm 0.25pF	CD-0X5CJBC	C2C31P1HCG0R5C
C5	Chip	2pF	50WV	\pm 0.5pF	CD-020DJBC	C2C31P1HCG020D
C6	Chip	0.5pF	50WV	\pm 0.25pF	CD-0X5CJBC	C2C31P1HCG0R5C
C7	Chip	2pF	50WV	\pm 0.5pF	CD-020DJBC	C2C31P1HCG020D
C8	Chip	0.5pF	50WV	\pm 0.25pF	CD-0X5CJBC	C2C31P1HCG0R5C
C9	Chip	2pF	50WV	\pm 0.5pF	CD-020DJBC	C2C31P1HCG020D
C10	Chip	0.5pF	50WV	\pm 0.25pF	CD-0X5CJBC	C2C31P1HCG0R5C
C11	Chip	2pF	50WV	\pm 0.5pF	CD-020DJBC	C2C31P1HCG020D
C12	Chip	0.5pF	50WV	\pm 0.25pF	CD-0X5CJBC	C2C31P1HCG0R5C
C13	Chip	5pF	50WV	\pm 0.5pF	CD-050CJBC	C2C31P1HCG050D
C14	Chip	0.001 μ F	50WV	\pm 10%	CD-102KJBC	C3K31P1HC102K
C15	Chip	0.001 μ F	50WV	\pm 10%	CD-102KJBC	C3K31P1HC102K
C16	Chip	12pF	50WV	\pm 5%	CD-120JJBC	C2C31P1HCG120J
C17	Chip	6pF	50WV	\pm 0.5pF	CD-060DJBC	C2C31P1HCG060D
C18	Chip	6pF	50WV	\pm 0.5pF	CD-060DJBC	C2C31P1HCG060D
C19	Chip	6pF	50WV	\pm 0.5pF	CD-060DJBC	C2C31P1HCG060D
C20	Chip	12pF	50WV	\pm 5%	CD-120JJBC	C2C31P1HCG120J
C21	Chip	5pF	50WV	\pm 0.5pF	CD-050CJBC	C2C31P1HCG050D
C22	Chip	12pF	50WV	\pm 5%	CD-120JJBC	C2C31P1HCG120J
C23	Chip	15pF	50WV	\pm 5%	CD-150JJBC	C2C31P1HCG150J
C24	Chip	12pF	50WV	\pm 5%	CD-120JJBC	C2C31P1HCG120J
C25	Chip	10pF	50WV	\pm 0.5pF	CD-100DJBC	C2C31P1HCG100D
C26	Chip	0.001 μ F	50WV	\pm 10%	CD-120KJBC	C3K31P1HC102K
C27	Chip	0.001 μ F	50WV	\pm 10%	CD-102KJBC	C3K31P1HC102K
C28	Chip	12pF	50WV	\pm 5%	CD-120JJBC	C2C31P1HCG120J
C29	Chip	6pF	50WV	\pm 0.5pF	CD-060DJBC	C2C31P1HCG060D
C30	Chip	6pF	50WV	\pm 0.5pF	CD-060DJBC	C2C31P1HCG060D
C31	Chip	6pF	50WV	\pm 0.5pF	CD-060DJBC	C2C31P1HCG060D
C32	Chip	12pF	50WV	\pm 5%	CD-102JJBC	C2C31P1HCG120J
C33	Chip	8pF	50WV	\pm 0.5pF	CD-080CJBC	C2C31P1HCG080D
C34	Chip	22pF	50WV	\pm 5%	CD-220JJBC	C2C31P1HCG220J
C35	Chip	22pF	50WV	\pm 5%	CD-220JJBC	C2C31P1HCG220J
C36	Chip	22pF	50WV	\pm 5%	CD-220JJBC	C2C31P1HCG220J
C37	Chip	8pF	50WV	\pm 0.5pF	CD-080CJBC	C2C31P1HCG080D
C38	Chip	0.001 μ F	50WV	\pm 10%	CD-102KJBC	C3K31P1HC102K
C39	Chip	0.001 μ F	50WV	\pm 10%	CD-102KJBC	C3K31P1HC102K
C40	Chip	27pF	50WV	\pm 5%	CD-270JJBC	C2C31P1HCG270J
C41	Chip	12pF	50WV	\pm 5%	CD-120JJBC	C2C31P1HCG120J
C42	Chip	12pF	50WV	\pm 5%	CD-120JJBC	C2C31P1HCG120J
C43	Chip	12pF	50WV	\pm 5%	CD-120JJBC	C2C31P1HCG120J
C44	Chip	27pF	50WV	\pm 5%	CD-270JJBC	C2C31P1HCG270J
C45	Chip	22pF	50WV	\pm 5%	CD-220JJBC	C2C31P1HCG220J
C46	Chip	39pF	50WV	\pm 5%	CD-390JJBC	C2C31P1HCG390J
C47	Chip	47pF	50WV	\pm 5%	CD-470JJBC	C2C31P1HCG470J
C48	Chip	39pF	50WV	\pm 5%	CD-390JJBC	C2C31P1HCG390J
C49	Chip	22pF	50WV	\pm 5%	CD-220JJBC	C2C31P1HCG220J
C50	Chip	0.001 μ F	50WV	\pm 10%	CD-102KJBC	C3K31P1HC102K
C51	Chip	0.001 μ F	50WV	\pm 10%	CD-102KJBC	C3K31P1HC102K
C52	Chip	39pF	50WV	\pm 5%	CD-390JJBC	C2C31P1HCG390J

Ref. No.	Description				RS Part Number	MFR's Part Number
C53	Chip	18pF	50WV	±5%	CD-180JJBC	C2C31P1HCG180J
C54	Chip	18pF	50WV	±5%	CD-180JJBC	C2C31P1HCG180J
C55	Chip	18pF	50WV	±5%	CD-180JJBC	C2C31P1HCG180J
C56	Chip	39pF	50WV	±5%	CD-390JJBC	C2C31P1HCG390J
C57	Chip	33pF	50WV	±5%	CD-330JJBC	C2C31P1HCG330J
C58	Chip	68pF	50WV	±5%	CD-680JJBC	C2C31P1HCG680J
C59	Chip	68pF	50WV	±5%	CD-680JJBC	C2C31P1HCG680J
C60	Chip	68pF	50WV	±5%	CD-680JJBC	C2C31P1HCG680J
C61	Chip	22pF	50WV	±5%	CD-220JJBC	C2C31P1HCG220J
C62	Chip	0.001μF	50WV	±10%	CD-102KJBC	C3K31P1HC102K
C63	Chip	0.001μF	50WV	±10%	CD-102KJBC	C3K31P1HC102K
C64	Chip	68pF	50WV	±5%	CD-680JJBC	C2C31P1HCG680J
C65	Chip	27pF	50WV	±5%	CD-270JJBC	C2C31P1HCG270J
C66	Chip	27pF	50WV	±5%	CD-270JJBC	C2C31P1HCG270J
C67	Chip	68pF	50WV	±5%	CD-680JJBC	C2C31P1HCG680J
C68	Chip	47pF	50WV	±5%	CD-470JJBC	C2C31P1HCG470J
C69	Chip	100pF	50WV	±5%	CD-101JJBC	C2C31P1HCG101J
C70	Chip	100pF	50WV	±5%	CD-101JJBC	C2C31P1HCG101J
C71	Chip	100pF	50WV	±5%	CD-101JJBC	C2C31P1HCG101J
C72	Chip	27pF	50WV	±5%	CD-270JJBC	C2C31P1HCG270J
C73	Chip	0.001μF	50WV	±10%	CD-102KJBC	C3K31P1HC102K
C74	Chip	0.001μF	50WV	±10%	CD-102KJBC	C3K31P1HC102K
C75	Chip	220pF	50WV	±5%	CD-221JJBC	C2C31P1HCG221J
C76	Chip	47pF	50WV	±5%	CD-470JJBC	C2C31P1HCG470J
C77	Chip	68pF	50WV	±5%	CD-680JJBC	C2C31P1HCG680J
C78	Chip	68pF	50WV	±5%	CD-680JJBC	C2C31P1HCG680J
C79	Chip	150pF	50WV	±5%	CD-151JJBC	C2C31P1HCG151J
C80	Chip	20pF	50WV	±5%	CD-200JJBC	C2C31P1HCG200J
C81	Chip	150pF	50WV	±5%	CD-151JJBC	C2C31P1HCG151J
C82	Chip	20pF	50WV	±5%	CD-200JJBC	C2C31P1HCG200J
C83	Chip	150pF	50WV	±5%	CD-151JJBC	C2C31P1HCG151J
C84	Chip	20pF	50WV	±5%	CD-200JJBC	C2C31P1HCG200J
C85	Chip	47pF	50WV	±5%	CD-470JJBC	C2C31P1HCG470J
C86	Chip	0.001μF	50WV	±10%	CD-102KJBC	C3K31P1HC102K
C87	Chip	0.001μF	50WV	±10%	CD-102KJBC	C3K31P1HC102K
C88	Chip	0.01μF	50WV	±10%	CD-103KJBC	C3K31P1HC103K
C89	Chip	100pF	50WV	±5%	CD-101JJBC	C2C31P1HCG101J
C90	Chip	10pF	50WV	±0.5pF	CD-100DJBC	C2C31P1HCG100D
C91	Chip	100pF	50WV	±5%	CD-101JJBC	C2C31P1HCG101J
C92	Chip	4pF	50WV	±0.5pF	CD-040CJBC	C2C31P1HCG040D
C93	Chip	10pF	50WV	±0.5pF	CD-100DJBC	C2C31P1HCG100D
C94	Chip	0.001μF	50WV	±10%	CD-102KJBC	C3K31P1HC102K
C95	Chip	5pF	50WV	±0.5pF	CD-050CJBC	C2C31P1HCG050D
C96	Chip	100pF	50WV	±5%	CD-101JJBC	C2C31P1HCG101J
C97	Chip	6pF	50WV	±0.5pF	CD-060DJBC	C2C31P1HCG060D
C98	Chip	2pF	50WV	±0.5pF	CD-020DJBC	C2C31P1HCG020D
C99	Chip	100pF	50WV	±5%	CD-101JJBC	C2C31P1HCG101J
C100	Chip	100pF	50WV	±5%	CD-101JJBC	C2C31P1HCG101J
C101	Chip	0.001μF	50WV	±10%	CD-102KJBC	C3K31P1HC102K
C102	Chip	33pF	50WV	±5%	CD-330JJBC	C2C31P1HCG330J
C103	Chip	0.001μF	50WV	±10%	CD-102KJBC	C3K31P1HC102K
C104	Chip	22pF	50WV	±5%	CD-220JJBC	C2C31P1HCG220J
C105	Chip	0.01μF	50WV	±10%	CD-103KJBC	C3K31P1HC103K
C106	Chip	470pF	50WV	±5%	CC-471JJBC	C2C31P1HCG471J
C107	Chip	33pF	50WV	±5%	CD-330JJBC	C2C31P1HCG330J
C108	Chip	33pF	50WV	±5%	CD-330JJBC	C2C31P1HCG330J
C109	Chip	22pF	50WV	±5%	CD-220JJBC	C2C31P1HCG220J

Ref. No.	Description				RS Part Number	MFR's Part Number
C110	Chip	10pF	50WV	±0.5pF	CD-100DJBC	C2C31P1HCG100D
C111	Chip	0.001μF	50WV	±10%	CD-102KJBC	C3K31P1HC102K
C112	Chip	5pF	50WV	±0.5pF	CC-050CJBC	C2C31P1HCG050D
C113	Chip	18pF	50WV	±5%	CD-180JJBC	C2C31P1HCG180J
C114	Chip	0.001μF	50WV	±10%	CD-102KJBC	C3K31P1HC102K
C115	Chip	33pF	50WV	±5%	CC-330JJBC	C2C31P1HCG330J
C116	Ceramic	0.001μF	50WV	±10%	CC-102KJBC	HE50SJYB102K
C117	Ceramic	0.001μF	50WV	±10%	CC-102KJBC	HE50SJYB102K
C118	Electrolytic	10μF	16WV	±20%	CC-106MDCA	16MV100HA
C119	Electrolytic	33μF	16WV	±20%	CC-336MDCA	16MV330HA
C120	Chip	2pF	50WV	±0.5pF	CD-020DJBC	C2C31P1HCG020D
C121	Ceramic	0.001μF	50WV	±10%	CC-102KJBC	HE50SJYB102K
C122	Ceramic	10pF	50WV	±0.5pF	CC-100DJBC	HE40SJS�100D
C123	Ceramic	10pF	50WV	±10%	CC-100DJBC	HE40SJUJ100K
C124	Ceramic	1pF	50WV	±0.5pF	CC-010CJBC	HE40SJCH010D
C125	Ceramic	10pF	50WV	±10%	CC-100DJBC	HE40SJUJ100K
C126	Ceramic	0.001μF	50WV	±10%	CC-102KJBC	HE50SJYB102K
C127	Ceramic	0.001μF	50WV	±10%	CC-102KJBC	HE50SJYB102K
C128	Ceramic	10pF	50WV	±0.5pF	CC-100DJBC	HE40SJS�100D
C129	Chip	2pF	50WV	±0.5pF	CC-020DJBC	C2C31P1HCG020D
C130	Ceramic	22pF	50WV	±10%	CC-220KJBC	HE40SJS�220K
C131	Ceramic	56pF	50WV	±10%	CC-560JJBC	HE40SJS�560K
C132	Ceramic	0.001μF	50WV	±10%	CC-102KJBC	HE50SJYB102K
C133	Ceramic	0.001μF	50WV	±10%	CC-102KJBC	HE50SJYB102K
C134	Ceramic	0.001μF	50WV	±10%	CC-102KJBC	HE50SJYB102K
C135	Ceramic	0.001μF	50WV	±10%	CC-102KJBC	HE50SJYB102K
C136	Ceramic	0.001μF	50WV	±10%	CC-102KJBC	HE50SJYB102K
C137	Mylar*	0.047μF	50WV	±10%	CC-473KJBM	AK1-UU473K50
C138	Mylar	0.047μF	50WV	±10%	CC-473KJBM	AK1-UU473K50
C139	Mylar	0.1μF	50WV	±10%	CC-104KJBM	AK1-UU104K50
C140	Ceramic	470pF	50WV	±10%	CC-471KJBC	HE40SJYB471K
C141	Ceramic	100pF	50WV	±10%	CC-101KJBC	HE40SJYB101K
C142	Ceramic	470pF	50WV	±10%	CC-471KJBC	HE40SJYB471K
C143	Mylar	0.0022μF	50WV	±10%	CC-222KJBM	AK1-UU222K50
C144	Electrolytic	10μF	16WV	±20%	CC-106MDCA	16MV100HA
C145	Ceramic	47pF	50WV	±10%	CC-470KJBC	HE40SJS�470K
C146	Mylar	0.047μF	50WV	±10%	CC-473KJBM	AK1-UU473K50
C147	Ceramic	470pF	50WV	±10%	CC-471KJBC	HE40SJYB471K
C148	Electrolytic	1μF	50WV	±20%	CC-105MJBA	50MV010HA
C149	Electrolytic	10μF	16WV	±20%	CC-106MDCA	16MV100HA
C150	Ceramic	0.01μF	50WV	+80%—20%	CC-103ZJBC	HE70SJYF103Z
C151	Electrolytic	1μF	50WV	±20%	CC-105MJBA	50MV010HA
C152	Electrolytic	10μF	16WV	±20%	CC-106MDCA	16MV100HA
C153	Mylar	0.056μF	50WV	±10%	CC-563KJBM	AK1-UU563K50
C154	Electrolytic	22μF	16WV	±20%	CC-226MDCA	16MV220HA
C155	Electrolytic	1μF	50WV	±20%	CC-105MJBA	50MV010HA
C156	Electrolytic	1μF	50WV	±20%	CC-105MJBA	50MV010HA
C157	Ceramic	33pF	50WV	±10%	CC-330KJBC	HE40SJS�330K
C158	Not used					
C159	Not used					
C160	Not used					
C161	Ceramic	0.001μF	50WV	±10%	CC-102KJBC	HE50SJYB102K
C162	Ceramic	0.01μF	50WV	+80%—20%	CC-103ZJBC	HE70SJYF103Z
C163	Ceramic	0.01μF	50WV	+80%—20%	CC-103ZJBC	HE70SJYF103Z
C164	Ceramic	0.001μF	50WV	±10%	CC-102KJBC	HE50SJYB102K
C165	Ceramic	0.001μF	50WV	±10%	CC-102KJBC	HE50SJYB102K
C166	Ceramic	0.01μF	50WV	+80%—20%	CC-103ZJBC	HE70SJYF103Z

* Mylar is a registered trademark of E.I. Du Pont de Nemours and Company.

Ref. No.	Description				RS Part Number	MFR's Part Number
C167	Ceramic	0.001 μ F	50WV	\pm 10%	CC-102KJBC	HE50SJYB102K
C168	Ceramic	10pF	50WV	\pm 10%	CC-100DJBC	HE40SJUJ100K
C169	Ceramic	0.001 μ F	50WV	\pm 10%	CC-102KJBC	HE50SJYB102K
C170	Ceramic	33pF	50WV	\pm 10%	CC-330KJBC	HE40SJS�330K
C171	Ceramic	10pF	50WV	\pm 0.5pF	CC-100DJBC	HE40SJS�100D
C172	Ceramic	0.001 μ F	50WV	\pm 10%	CC-102KJBC	HE50SJYB102K
C173	Ceramic	10pF	50WV	\pm 0.5pF	CC-100DJBC	HE40SJS�100D
C174	Tantalum	0.47 μ F	35WV	\pm 20%	CC-474MGBT	DN1VR47M1S
C175	Ceramic	0.047 μ F	50WV	+80%—20%	CC-473ZJBC	HE13SJYF473Z
C176	Tantalum	0.1 μ F	35WV	\pm 20%	CC-104MGBT	DN1V0R1M1S
C177	Ceramic	0.01 μ F	50WV	+80%—20%	CC-103ZJBC	HE70SJYF103Z
C178	Electrolytic	220 μ F	16WV	\pm 20%	CC-227MDCA	16MV221HA
C179	Ceramic	10pF	50WV	\pm 0.5pF	CC-100DJBC	HE40SJS�100D
C180	Chip	5pF	50WV	\pm 0.5pF	CD-050DJBC	C2C31P1HCG050D
C181	Tantalum	0.22 μ F	35WV	\pm 20%	CC-224MGBT	DN1VR22M1S
C182	Mylar	0.01 μ F	50WV	\pm 10%	CC-103KJBM	AK1-UU103K50
C183	Ceramic	5pF	50WV	\pm 0.5pF	CC-050CJBC	HE40SJS�050D
C184	Mylar	0.0068 μ F	50WV	\pm 10%	CC-682KJBM	AK1-UU682K50
C185	Ceramic	470pF	50WV	\pm 10%	CC-471KJBC	HE40SJYB471K
C186	Ceramic	470pF	50WV	\pm 10%	CC-471KJBC	HE40SJYB471K
C187	Tantalum	0.1 μ F	35WV	\pm 20%	CC-104MGBT	DN1V0R1M1S
C188	Ceramic	0.01 μ F	50WV	+80%—20%	CC-103ZJBC	HE70SJYF103Z
C189	Mylar	0.047 μ F	50WV	\pm 10%	CC-473KJBM	AK1-UU473K50
C190	Electrolytic	0.1 μ F	50WV	\pm 20%	CC-104MJBA	50MVR10HA
C191	Electrolytic	1 μ F	50WV	\pm 20%	CC-105MJBA	50MV010HA
C192	Mylar	0.056 μ F	50WV	\pm 10%	CC-563KJBM	AK1-UU563K50
C193	Electrolytic	0.1 μ F	50WV	\pm 20%	CC-104MJBA	50MVR10HA
C194	Mylar	0.056 μ F	50WV	\pm 10%	CC-563KJBM	AK1-UU563K50
C195	Electrolytic	4.7 μ F	25WV	\pm 20%	CC-475MFBA	25MV4R7HA
C196	Tantalum	0.1 μ F	35WV	\pm 20%	CC-104MGBT	DN1V0R1M1S
C197	Ceramic	0.01 μ F	50WV	+80%—20%	CC-103ZJBC	HE70SJYF103Z
C198	Electrolytic	1 μ F	50WV	\pm 20%	CC-105MJBA	50MV010HA
C199	Ceramic	330pF	50WV	\pm 10%	CC-331KJBC	HE40SJYB331K
C200	Mylar	0.082 μ F	50WV	\pm 10%	CC-823KJBM	AK1-UU823K50
C201	Mylar	0.056 μ F	50WV	\pm 10%	CC-563KJBM	AK1-UU563K50
C202	Mylar	0.0047 μ F	50WV	\pm 10%	CC-472KJBM	AK1-UU472K50
C203	Mylar	0.047 μ F	50WV	\pm 10%	CC-473KJBM	AK1-UU473K50
C204	Ceramic	0.0015 μ F	50WV	\pm 10%	CC-152KJBC	HE60SJYB152K
C205	Mylar	0.0068 μ F	50WV	\pm 10%	CC-682KJBM	AK1-UU682K50
C206	Mylar	0.0068 μ F	50WV	\pm 10%	CC-682KJBM	AK1-UU682K50
C207	Mylar	0.047 μ F	50WV	\pm 10%	CC-473KJBM	AK1-UU473K50
C208	Electrolytic	2.2 μ F	50WV	\pm 20%	CC-225MJBA	50MV2R2HA
C209	Ceramic	0.01 μ F	50WV	+80%—20%	CC-103ZJBC	HE70SJYF103Z
C210	Electrolytic	1 μ F	50WV	\pm 20%	CC-105MJBA	50MV010SS
C211	Electrolytic	1000 μ F	25WV	\pm 20%	CC-108MFBA	25MV102HA
C212	Electrolytic	47 μ F	16WV	\pm 20%	CC-476MDCA	16MV470SS
C213	Electrolytic	100 μ F	16WV	\pm 20%	CC-107MDCA	16MV101HA
C214	Mylar	0.22 μ F	50WV	\pm 10%	CC-224KJBM	AK1-UU224K50
C215	Electrolytic	10 μ F	16WV	\pm 20%	CC-106MDCA	16MV100SS
C216	Electrolytic	2.2 μ F	50WV	\pm 20%	CC-225MJBA	50MV2R2SS
C217	Electrolytic	10 μ F	50WV	\pm 20%	CC-106MJBA	50MV100HA
C218	Electrolytic	33 μ F	16WV	\pm 20%	CC-336MDCA	16MV330HA
C219	Ceramic	0.047 μ F	50WV	+80%—20%	CC-473ZJBC	HE13SJYF473Z
C220	Electrolytic	33 μ F	16WV	\pm 20%	CC-336MDCA	16MV330HA
C221	Tantalum	0.1 μ F	35WV	\pm 20%	CC-104MGBT	DN1V0R1M1S
C222	Tantalum	0.33 μ F	35WV	\pm 20%	CC-334MGBT	DN1VR33M1S
C223	Ceramic	0.001 μ F	50WV	\pm 10%	CC-102KJBC	HE50SJYB102K

Ref. No.	Description				RS Part Number	MFR's Part Number
C224	Electrolytic	220 μ F	16WV	\pm 20%	CC-227MDCA	16MV221HA
C225	Mylar	0.033 μ F	50WV	\pm 10%	CC-333KJBM	AK1-UU333K50
C226	Electrolytic	220 μ F	16WV	\pm 20%	CC-227MDCA	16MV221HA
C227	Electrolytic	100 μ F	16WV	\pm 20%	CC-107MDCA	16MV101HA
C228	Electrolytic	0.1 μ F	50WV	\pm 20%	CC-104MJBA	50MVR10SS
C229	Electrolytic	0.1 μ F	50WV	\pm 20%	CC-104MJBA	50MVR10SS
C230	Electrolytic	10 μ F	16WV	\pm 20%	CC-106MDCA	16MV100HA
C231	Ceramic	0.01 μ F	50WV	+80%—20%	CC-103ZJBC	HE70SJYF103Z
C232	Not used					
△ C233	Electrolytic	2200 μ F	25WV	\pm 20%	CC-228MFBA	25MV222HA
C234	Electrolytic	470 μ F	25WV	\pm 20%	CC-477MFBA	25MV471HA
C235	Chip	2pF	50WV	\pm 0.5pF	CD-020DJBC	C2C31P1HCG020D
C236	Mylar	0.022 μ F	50WV	\pm 10%	CC-273KJBM	AK1-UU223K50
C237	Chip	0.001 μ F	50WV	\pm 10%	CD-102KJBC	C3K31P1HC102K
C238	Chip	5pF	50WV	\pm 0.5pF	CD-050CJBC	C2C31P1HCG050D
C239	Not used					
C240	Electrolytic	33 μ F	16WV	\pm 20%	CC-336MDCA	16MV330HA
C241	Chip	0.001 μ F	50WV	\pm 10%	CD-102KJBC	C3K31P1HC102K
C242	Electrolytic	1 μ F	50WV	\pm 20%	CC-105MJBA	50MV010HA
C243	Electrolytic	1 μ F	50WV	\pm 20%	CC-105MJBA	50MV010HA
C244	Electrolytic	1 μ F	50WV	\pm 20%	CC-105MJBA	50MV010HA
C245	Electrolytic	1 μ F	50WV	\pm 20%	CC-105MJBA	50MV010HA
C246	Electrolytic	1 μ F	50WV	\pm 20%	CC-105MJBA	50MV010HA
C247	Electrolytic	1 μ F	50WV	\pm 20%	CC-105MJBA	50MV010HA
C248	Electrolytic	1 μ F	50WV	\pm 20%	CC-105MJBA	50MV010HA
C301	Ceramic	0.001 μ F	50WV	\pm 10%	CC-102KJBC	HE50SJYB102K
C302	Ceramic	0.001 μ F	50WV	\pm 10%	CC-102KJBC	HE50SJYB102K
C303	Ceramic	0.001 μ F	50WV	\pm 10%	CC-102KJBC	HE50SJYB102K
C304	Ceramic	0.001 μ F	50WV	\pm 10%	CC-102KJBC	HE50SJYB102K
C305	Ceramic	0.001 μ F	50WV	\pm 10%	CC-102KJBC	HE50SJYB102K
C306	Ceramic	0.001 μ F	50WV	\pm 10%	CC-102KJBC	HE50SJYB102K
C307	Chip	2pF	50WV	\pm 0.5pF	CD-020DJBC	C2C31P1HCG020D
C308	Ceramic	0.001 μ F	50WV	\pm 10%	CC-102KJBC	HE50SJYB102K
C309	Ceramic	0.001 μ F	50WV	\pm 10%	CC-102KJBC	HE50SJYB102K
C310	Ceramic	0.001 μ F	50WV	\pm 10%	CC-102KJBC	HE50SJYB102K
C311	Ceramic	5pF	50WV	\pm 0.5pF	CC-050CJBC	HE40SJSLO50D
C312	Chip	3pF	50WV	\pm 0.5pF	CD-030CJBC	C2C31P1HCG030D
C313	Chip	5pF	50WV	\pm 0.5pF	CD-050CJBC	C2C31P1HCG050D
C314	Ceramic	0.001 μ F	50WV	\pm 10%	CC-102KJBC	HE50SJYB102K
C315	Chip	4pF	50WV	\pm 0.5pF	CD-040CJBC	C2C31P1HCG040D
C316	Chip	10pF	50WV	\pm 0.5pF	CD-100DJBC	C2C31P1HCG100D
C317	Ceramic	0.001 μ F	50WV	\pm 10%	CC-102KJBC	HE50SJYB102K
C318	Chip	5pF	50WV	\pm 0.5pF	CD-050CJBC	C2C31P1HCG050D
C319	Ceramic	1pF	50WV	\pm 0.5pF	CC-010CJBC	HE40SJSLO10D
C320	Chip	5pF	50WV	\pm 0.5pF	CD-050CJBC	C2C31P1HCG050D
C321	Ceramic	0.001 μ F	50WV	\pm 10%	CC-102KJBC	HE50SJYB102K
C322	Chip	1pF	50WV	\pm 0.25pF	CD-010CJBC	C2C31P1HCG010C
C323	Ceramic	0.001 μ F	50WV	\pm 10%	CC-102KJBC	HE50SJYB102K
C324	Chip	0.5pF	50WV	\pm 0.25pF	CD-0X5CJBC	C2C31P1HCG0R5C
C325	Chip	2pF	50WV	\pm 0.5pF	CD-020DJBC	C2C31P1HCG020D
C326	Chip	1pF	50WV	\pm 0.25pF	CD-010CJBC	C2C31P1HCG010C
C327	Chip	1pF	50WV	\pm 0.25pF	CD-010CJBC	C2C31P1HCG010C
C328	Chip	1pF	50WV	\pm 0.25pF	CD-010CJBC	C2C31P1HCG010C
C329	Chip	2pF	50WV	\pm 0.5pF	CD-020DJBC	C2C31P1HCG020D
C330	Ceramic	0.001 μ F	50WV	\pm 10%	CC-102KJBC	HE50SJYB102K
C331	Chip	3pF	50WV	\pm 0.5pF	CD-030CJBC	C2C31P1HCG030D
C332	Ceramic	0.001 μ F	50WV	\pm 10%	CC-102KJBC	HE50SJYB102K

Ref. No.	Description				RS Part Number	MFR's Part Number
C333	Ceramic	5pF	50WV	±0.5pF	CC-050CJBC	HE40SJSLO50D
C334	Ceramic	0.001μF	50WV	±10%	CC-102KJBC	HE50SJYB102K
C335	Chip	2pF	50WV	±0.5pF	CD-020DJBC	C2C31P1HCG020D
C336	Chip	2pF	50WV	±0.5pF	CD-020DJBC	C2C31P1HCG020D
C337	Ceramic	0.001μF	50WV	±10%	CC-102KJBC	HE50SJYB102K
C338	Chip	5pF	50WV	±0.5pF	CD-050CJBC	C2C31P1HCG050D
C339	Not used					
C340	Chip	22pF	50WV	±0.5pF	CD-220DJBC	C2C31P1HCG220D
C341	Ceramic	22pF	50WV	±10%	CC-220KJBC	HE40SJS�220K
C342	Ceramic	0.001μF	50WV	±10%	CC-102KJBC	HE50SJYB102K
C343	Electrolytic	10μF	16WV	±20%	CC-106MDCA	16MV100HA
C344	Electrolytic	10μF	16WV	±20%	CC-106MDCA	16MV100HA
C345	Chip	0.001μF	50WV	±10%	CD-102KJBC	C3K31P1HC102K
C346	Chip	22pF	50WV	±0.5pF	CD-220DJBC	C2C31P1HCG220D
C347	Chip	2pF	50WV	±0.5pF	CD-020DJBC	C2C31P1HCG020D
C348	Chip	5pF	50WV	±0.5pF	CD-050CJBC	C2C31P1HCG050D
C349	Chip	10pF	50WV	±0.5pF	CD-100DJBC	C2C31P1HCG100D
C350	Mylar	0.047μF	50WV	±10%	CC-473KJBM	AK1-UU473K50
C351	Tantalum	0.1μF	35WV	±20%	CC-104MGBT	DN1V0R1M1S
C352	Ceramic	0.001μF	50WV	±10%	CC-102KJBC	HE50SJYB102K
C353	Chip	4pF	50WV	±0.5pF	CD-040CJBC	C2C31P1HCG040D
C354	Chip	10pF	50WV	±0.5pF	CD-100DJBC	C2C31P1HCG100D
C355	Not used					
C356	Chip	0.5pF	50WV	±0.25pF	CD-0X5CJBC	C2C31P1HCG0R5C
C357	Ceramic	33pF	50WV	±10%	CC-330KJBC	HE40SJS�330K
C358	Ceramic	0.001μF	50WV	±10%	CC-102KJBC	HE50SJYB102K
C359	Ceramic	0.001μF	50WV	±10%	CC-102KJBC	HE50SJYB102K
C360	Ceramic	100pF	50WV	±10%	CC-101KJBC	HE50SJS�101K
C361	Chip	2pF	50WV	±0.5pF	CD-020DJBC	C2C31P1HCG020D
C362	Chip	6pF	50WV	±0.5pF	CD-060DJBC	C2C31P1HCG060D
C363	Chip	10pF	50WV	±0.5pF	CD-100DJBC	C2C31P1HCG100D
C364	Chip	10pF	50WV	±0.5pF	CD-100DJBC	C2C31P1HCG100D
C365	Ceramic	33pF	50WV	±10%	CC-330KJBC	HE40SJS�330K
C366	Ceramic	0.001μF	50WV	±10%	CC-102KJBC	HE50SJYB102K
C367	Electrolytic	220μF	16WV	±20%	CC-227MDCA	16MV221HA
C368	Ceramic	0.001μF	50WV	±10%	CD-102KJBC	HE50SJYB102K
C369	Tantalum	0.47μF	35WV	±20%	CC-474MGBT	DN1VR47M1S
C370	Mylar	0.047μF	50WV	±10%	CC-473KJBM	AK1-UU473K50
C371	Ceramic	0.001μF	50WV	±10%	CC-102KJBC	HE50SJYB102K
C372	Ceramic	0.001μF	50WV	±10%	CC-102KJBC	HE50SJYB102K
C373	Chip	1pF	50WV	±0.25pF	CD-010CJBC	C2C31P1HCG010C
C374	Chip	5pF	50WV	±0.5pF	CD-050CJBC	C2C31P1HCG050D
C375	Not used					
C376	Ceramic	22pF	50WV	±10%	CC-220KJBC	HE40SJS�220K
C377	Ceramic	5pF	50WV	±0.5pF	CC-050CJBC	HE40SJSLO50D
C378	Ceramic	0.001μF	50WV	±10%	CC-102KJBC	HE50SJYB102K
C379	Ceramic	100pF	50WV	±10%	CC-101KJBC	HE50SJS�101K
C380	Ceramic	0.01μF	50WV	+80%—20%	CC-103ZJBC	HE70SJYF103Z
C381	Ceramic	0.001μF	50WV	±10%	CC-102KJBC	HE50SJYB102K
C382	Ceramic	0.0022μF	50WV	±10%	CC-222KJBC	HE60SJYB222K
C383	Ceramic	0.01μF	50WV	+80%—20%	CC-103ZJBC	HE70SJYF103Z
C384	Ceramic	0.001μF	50WV	±10%	CC-102KJBC	HE50SJYB102K
C385	Not used					
C386	Mylar	0.047μF	50WV	±10%	CC-473KJBM	AK1-UU473K50
C387	Ceramic	0.001μF	50WV	±10%	CC-102KJBC	HE50SJYB102K
C388	Ceramic	0.01μF	50WV	+80%—20%	CC-103ZJBC	HE70SJYF103Z
C389	Tantalum	0.1μF	35WV	±20%	CC-104MGBT	DN1V0R1M1S

Ref. No.	Description				RS Part Number	MFR's Part Number
C390	Not used					
C391	Not used					
C392	Ceramic	0.001 μ F	50WV	\pm 10%	CC-102KJBC	HE50SJYB102K
C393	Ceramic	0.001 μ F	50WV	\pm 10%	CC-102KJBC	HE50SJYB102K
C394	Not used					
C395	Electrolytic	10 μ F	50WV	\pm 20%	CC-106MJBA	50MV100HA
C396	Ceramic	0.001 μ F	50WV	\pm 10%	CC-102KJBC	HE50SJYB102K
C397	Ceramic	0.01 μ F	50WV	+80%—20%	CC-103ZJBC	HE70SJYF103Z
C398	Ceramic	0.001 μ F	50WV	\pm 10%	CC-102KJBC	HE50SJYB102K
C399	Electrolytic	220 μ F	16WV	\pm 20%	CC-227MDCA	16MV221HA
C400	Ceramic	0.001 μ F	50WV	\pm 10%	CC-102KJBC	HE50SJYB102K
C401	Ceramic	0.001 μ F	50WV	\pm 10%	CC-102KJBC	HE50SJYB102K
C402	Tantalum	0.33 μ F	35WV	\pm 20%	CC-334MGBT	DN1VR33M1S
C403	Tantalum	0.1 μ F	35WV	\pm 20%	CC-104MGBT	DN1V0R1M1S
C404	Tantalum	0.33 μ F	35WV	\pm 20%	CC-334MGBT	DN1VR33M1S
C405	Tantalum	0.1 μ F	35WV	\pm 20%	CC-104MGBT	DN1V0R1M1S
C406	Chip	4pF	50WV	\pm 0.5pF	CD-040CJBC	C2C31P1HCG040D
C407	Chip	3pF	50WV	\pm 0.5pF	CD-030CJBC	C2C31P1HCG030D
C408	Not used					
C409	Chip	8pF	50WV	\pm 0.5pF	CD-080DJBC	C2C31P1HCG080D
C410	Not used					
C411	Chip	3pF	50WV	\pm 0.5pF	CD-030CJBC	C2C31P1HCG030D
C412	Not used					
C413	Chip	1pF	50WV	\pm 0.25pF	CD-010CJBC	C2C31P1HCG010C
C414	Chip	1pF	50WV	\pm 0.25pF	CD-010CJBC	C2C31P1HCG010C
C415	Not used					
C416	Chip	3pF	50WV	\pm 0.5pF	CD-030CJBC	C2C31P1HCG030D
C417	Not used					
C418	Chip	4pF	50WV	\pm 0.5pF	CD-040CJBC	C2C31P1HCG040D
C419	Chip	4pF	50WV	\pm 0.5pF	CD-040CJBC	C2C31P1HCG040D
C420	Ceramic	5pF	50WV	\pm 0.5pF	CC-050CJBC	HE40SJSLO50D
C421	Ceramic	0.001 μ F	50WV	\pm 10%	CC-102KJBC	HE50SJYB102K
C501	Ceramic	0.01 μ F	50WV	+80%—20%	CC-103ZJBC	HE70SJYF103Z
C502	Ceramic	0.01 μ F	50WV	+80%—20%	CC-103ZJBC	HE70SJYF103Z
C503	Ceramic	0.01 μ F	50WV	+80%—20%	CC-103ZJBC	HE70SJYF103Z
C504	Ceramic	100pF	50WV	\pm 10%	CC-101KJBC	HE40SJYB101K
C505	Ceramic	100pF	50WV	\pm 10%	CC-101KJBC	HE40SJYB101K
C506	Ceramic	100pF	50WV	\pm 10%	CC-101KJBC	HE40SJYB101K
C507	Ceramic	100pF	50WV	\pm 10%	CC-101KJBC	HE40SJYB101K
C508	Ceramic	0.001 μ F	50WV	\pm 10%	CC-102KJBC	HE50SJYB102K
C509	Ceramic	0.001 μ F	50WV	\pm 10%	CC-102KJBC	HE50SJYB102K
C510	Ceramic	0.001 μ F	50WV	\pm 10%	CC-102KJBC	HE50SJYB102K
C511	Ceramic	0.001 μ F	50WV	\pm 10%	CC-102KJBC	HE50SJYB102K
C512	Electrolytic	4.7 μ F	25WV	\pm 20%	CC-475MFBA	25MV4R7HA
C513	Not used					
C514	Not used					
C515	Ceramic	0.001 μ F	50WV	\pm 10%	CC-102KJBC	HE50SJYB102K
C516	Electrolytic	10 μ F	16WV	\pm 20%	CC-106MDCA	16MV100HA
C517	Ceramic	0.01 μ F	50WV	+80%—20%	CC-103ZJBC	HE70SJYF103Z
C518	Ceramic	0.01 μ F	50WV	+80%—20%	CC-103ZJBC	HE70SJYF103Z
C519	Ceramic	100pF	50WV	\pm 10%	CC-101KJBC	HE40SJYB101K
C701	Ceramic	0.01 μ F	50WV	+80%—20%	CC-103ZJBC	HE70SJYF103Z
C702	Ceramic	0.01 μ F	50WV	+80%—20%	CC-103ZJBC	HE70SJYF103Z
C703	Ceramic	0.01 μ F	50WV	+80%—20%	CC-103ZJBC	HE70SJYF103Z
C704	Electrolytic	100 μ F	16WV	\pm 20%	CC-107MDCA	16MV101SS
C705	Mylar	0.047 μ F	50WV	\pm 10%	CC-473KJBM	AK1-UU473K50
C706	Tantalum	6.8 μ F	10WV	\pm 20%	CC-685MCBT	DN1A6R8M1S

CAPACITOR ARRAY					
Ref. No.	Description			RS Part Number	MFR's Part Number
CA501	0.001 μ Fx8	50WV	+80%—20%		EXF-P8102ZF
CA502	100pFx6	50WV	\pm 20%	C-1814	EXF-P6101MF
CA503	100pFx12	50WV	\pm 20%	C-1815	EXF-P12101MF
CA504	100pFx12	50WV	\pm 20%	C-1815	EXF-P12101MF
CB1	0.01 μ Fx2	250V	+80%—20%	CA-1816	EXR-FS203ZS
CB2	0.01 μ Fx2	250V	+80%—20%	CA-1816	EXR-FS203ZS

DIODE					
Ref. No.	Description			RS Part Number	MFR's Part Number
D1	1SS241	(Silicon)		DX-2771	1SS241
D2	1SS241	(Silicon)		DX-2771	1SS241
D3	1SS241	(Silicon)		DX-2771	1SS241
D4	1SS241	(Silicon)		DX-2771	1SS241
D5	1SS241	(Silicon)		DX-2771	1SS241
D6	1SS241	(Silicon)		DX-2771	1SS241
D7	1SS241	(Silicon)		DX-2771	1SS241
D8	1SS241	(Silicon)		DX-2771	1SS241
D9	1SS241	(Silicon)		DX-2771	1SS241
D10	1SS241	(Silicon)		DX-2771	1SS241
D11	1SS241	(Silicon)		DX-2771	1SS241
D12	1SS241	(Silicon)		DX-2771	1SS241
D13	1SS241	(Silicon)		DX-2771	1SS241
D14	1SS241	(Silicon)		DX-2771	1SS241
D15	1SS241	(Silicon)		DX-2771	1SS241
D16	1SS241	(Silicon)		DX-2771	1SS241
D17	1SS241	(Silicon)		DX-2771	1SS241
D18	1SS241	(Silicon)		DX-2771	1SS241
D19	1SS241	(Silicon)		DX-2771	1SS241
D20	1SS241	(Silicon)		DX-2771	1SS241
D21	1SS241	(Silicon)		DX-2771	1SS241
D22	1SS241	(Silicon)		DX-2771	1SS241
D23	1SS241	(Silicon)		DX-2771	1SS241
D24	1SS241	(Silicon)		DX-2771	1SS241
D25	1SS241	(Silicon)		DX-2771	1SS241
D26	1SS241	(Silicon)		DX-2771	1SS241
D27	1SS241	(Silicon)		DX-2771	1SS241
D28	ND487C1-3R	(Silicon)		DX-2773	ND487C1-3R
D29	1SS241	(Silicon)		DX-2771	1SS241
D30	1SS241	(Silicon)		DX-2771	1SS241
D31	OA90-R	(Germanium)		DX-2772	OA90-R
D32	OA90-R	(Germanium)		DX-2772	OA90-R
D33	OA90-R	(Germanium)		DX-2772	OA90-R
D34	1S2076A	(Silicon)		DX-1056	1S2076A
D35	1S2076A	(Silicon)		DX-1056	1S2076A
D36	1S2076A	(Silicon)		DX-1056	1S2076A

Ref. No.	Description	RS Part Number	MFR's Part Number
D37	1S2076A (Silicon)	DX-1056	1S2076A
D38	1S2076A (Silicon)	DX-1056	1S2076A
D39	1S2076A (Silicon)	DX-1056	1S2076A
D40	1S2076A (Silicon)	DX-1056	1S2076A
D41	1S2076A (Silicon)	DX-1056	1S2076A
D42	1S2076A (Silicon)	DX-1056	1S2076A
D43	1S2076A (Silicon)	DX-1056	1S2076A
D44	1S2076A (Silicon)	DX-1056	1S2076A
D45	1S2076A (Silicon)	DX-1056	1S2076A
D46	1S2076A (Silicon)	DX-1056	1S2076A
D47	1S2076A (Silicon)	DX-1056	1S2076A
D48	1S2076A (Silicon)	DX-1056	1S2076A
D49	Zener HZ6B2L (Silicon)	DX-2774	HZ6B2L
D50	Zener HZ9B2L (Silicon)	DX-2009	HZ9B2L
D51	1S2076A (Silicon)	DX-1056	1S2076A
D52	Zener HZ11B2L (Silicon)	DX-2687	HZ11B2L
D53	1S2076A (Silicon)	DX-1056	1S2076A
D54	SR1K-2 (Silicon)	DX-0475	SR1K-2
△ D55	Rectifier 1B4B41 (Silicon)	DX-2513	1B4B41
D56	1S1585 (Silicon)	DX-0636	1S1585
D57	1S1585 (Silicon)	DX-0636	1S1585
D301	1SS241 (Silicon)	DX-2771	1SS241
D302	1SS241 (Silicon)	DX-2771	1SS241
D303	1SS241 (Silicon)	DX-2771	1SS241
D304	1SS241 (Silicon)	DX-2771	1SS241
D305	Varactor 1T25(5/6/7) (Silicon)	DX-2775	1T25(5/6/7)
D306	Varactor 1T25(5/6/7) (Silicon)	DX-2775	1T25(5/6/7)
D307	Varactor 1T25(5/6/7) (Silicon)	DX-2775	1T25(5/6/7)
D308	Varactor 1T25(5/6/7) (Silicon)	DX-2775	1T25(5/6/7)
D309	Varactor 1SV89 (Silicon)	DX-0139	1SV89
D501	1S2076A (Silicon)	DX-1056	1S2076A
D502	1S2076A (Silicon)	DX-1056	1S2076A
D503	1S2076A (Silicon)	DX-1056	1S2076A
D504	1S2076A (Silicon)	DX-1056	1S2076A
D505	1S2076A (Silicon)	DX-1056	1S2076A
D506	1S2076A (Silicon)	DX-1056	1S2076A
D507	1S2076A (Silicon)	DX-1056	1S2076A
D508	1S2076A (Silicon)	DX-1056	1S2076A
D509	1S2076A (Silicon)	DX-1056	1S2076A
D510	Not used		
D511	Not used		
D512†	Not used		
D513	Not used		
D514	Not used		
D515	1S2076A (Silicon)	DX-1056	1S2076A
D701	LED TLR-208	L-0066	TLR-208

† See Appendix (page 54) for ITI models.

INTEGRATED CIRCUITS

Ref. No.	Description		RS Part Number	MFR's Part Number
IC1	KB4419A	(IF Amp/Det) (Bipolar) Linear	MX-7474	KB4419A
IC2	TK10420	(IF Amp/Quad/Det) (Bipolar) Linear	MX-4012	TK10420
IC3	HD14011BP	(Switching) (C-MOS) Logic	MX-5444	HD14011B
IC4	HD14066BP	(Switching/Mute) (C-MOS)	MX-5805	HD14066BP
IC5	μ PC324C	(Amp) (Bipolar)	MX-4373	μ PC324C
IC6	μ PC324C	(Zeromatic Cont) (Bipolar)	MX-4373	μ PC324C
IC7	TDA1905	(Audio Amp) (Bipolar)	MX-6439	TDA1905
IC8	HA17805P/ TA78005AP	(Voltage Regulator) (Bipolar)	MX-4760	HA17805P/ TA78005AP
IC9	S-81250HG	(Voltage Regulator) (C-MOS)	MX-7475	S-81250HG
IC301	MC145158	(PLL) (C-MOS)	MX-4014	MC145158
IC302	CX7925B	(PLL/Pre-Scaler) (N-MOS)	MX-6967	CX7925B
IC303	TD6127AP	(Pre-Scaler) (Bipolar)	MX-7476	TD6127AP
IC304	TD6105AP	(Pre-Scaler) (Bipolar)	MX-7477	TD6105AP
IC305	TA78L005AP	(Voltage Regulator) (Bipolar)	MX-6487	TA78L005AP
IC306	TA78L005AP	(Voltage Regulator) (Bipolar)	MX-6487	TA78L005AP
IC501	SN74LS145/ HD74LS145	(Decoder) (Bipolar)	MX-7479	SN74LS145/ HD74LS145
IC502	TD62504P	(Driver) (Bipolar)	MX-5593	TD62504P
IC503	GRE0327	(CPU) (C-MOS)	MX-7478	GRE0327
IC504	μ PD446G-45/ TC5517CF-20	(Memory Back Up) (C-MOS)	MX-7480	μ PD446G-45/ TC5517CF-20
IC701	μ PD7225G-00	(LCD Controller) (C-MOS)	MX-7481	μ PD7225G-00

COILS & TRANSFORMERS

Ref. No.	Description		RS Part Number	MFR's Part Number
L1	Coil, Trap	(609.5MHz)	CA-1216	GR-H761
L2	Not used			
L3	Coil, B.P.F	(280MHz to 520MHz)	CA-1219	2LNB-253
L4	Coil, B.P.F	(280MHz to 520MHz)	CA-1219	2LNB-253
L5	Coil, B.P.F	(280MHz to 520MHz)	CA-1219	2LNB-253
L6	Coil, B.P.F	(280MHz to 520MHz)	CA-1219	2LNB-253
L7	Coil, B.P.F	(280MHz to 520MHz)	CA-1219	2LNB-253
L8	Coil, B.P.F	(280MHz to 520MHz)	CA-1219	2LNB-253
L9	Coil, B.P.F	(280MHz to 520MHz)	CA-1219	2LNB-253
L10	Coil, B.P.F	(280MHz to 520MHz)	CA-1219	2LNB-253
L11	Not used			
L12	Coil, B.P.F	(174MHz to 279.995MHz)	CA-1220	2LNB-252
L13	Coil, B.P.F	(174MHz to 279.995MHz)	CA-1220	2LNB-252
L14	Coil, B.P.F	(174MHz to 279.995MHz)	CA-1220	2LNB-252
L15	Coil, B.P.F	(174MHz to 279.995MHz)	CA-1220	2LNB-252
L16	Coil, B.P.F	(174MHz to 279.995MHz)	CA-1220	2LNB-252
L17	Coil, B.P.F	(174MHz to 279.995MHz)	CA-1220	2LNB-252
L18	Coil, B.P.F	(174MHz to 279.995MHz)	CA-1220	2LNB-252
L19	Coil, B.P.F	(174MHz to 279.995MHz)	CA-1220	2LNB-252
L20	Not used			
L21	Coil, B.P.F	(108MHz to 173.995MHz)	CA-1221	3LNB-251
L22	Coil, B.P.F	(108MHz to 173.995MHz)	CA-1221	3LNB-251

Ref. No.	Description	RS Part Number	MFR's Part Number
L23	Coil, B.P.F (108MHz to 173.995MHz)	CA-1221	3LNB-251
L24	Coil, B.P.F (108MHz to 173.995MHz)	CA-1221	3LNB-251
L25	Coil, B.P.F (108MHz to 173.995MHz)	CA-1221	3LNB-251
L26	Coil, B.P.F (108MHz to 173.995MHz)	CA-1221	3LNB-251
L27	Coil, B.P.F (108MHz to 173.995MHz)	CA-1221	3LNB-251
L28	Coil, B.P.F (108MHz to 173.995MHz)	CA-1221	3LNB-251
L29	Not used		
L30	Coil, B.P.F (68MHz to 107.995MHz)	CA-1222	4LNB-250
L31	Coil, B.P.F (68MHz to 107.995MHz)	CA-1222	4LNB-250
L32	Coil, B.P.F (68MHz to 107.995MHz)	CA-1222	4LNB-250
L33	Coil, B.P.F (68MHz to 107.995MHz)	CA-1222	4LNB-250
L34	Coil, B.P.F (68MHz to 107.995MHz)	CA-1222	4LNB-250
L35	Coil, B.P.F (68MHz to 107.995MHz)	CA-1222	4LNB-250
L36	Coil, B.P.F (68MHz to 107.995MHz)	CA-1222	4LNB-250
L37	Coil, B.P.F (68MHz to 107.995MHz)	CA-1222	4LNB-250
L38	Not used		
L39	Coil, B.P.F (40MHz to 67.995MHz)	CA-1223	4LNB-249
L40	Coil, B.P.F (40MHz to 67.995MHz)	CA-1223	4LNB-249
L41	Coil, B.P.F (40MHz to 67.995MHz)	CA-1223	4LNB-249
L42	Coil, B.P.F (40MHz to 67.995MHz)	CA-1223	4LNB-249
L43	Coil, B.P.F (40MHz to 67.995MHz)	CA-1223	4LNB-249
L44	Coil, B.P.F (40MHz to 67.995MHz)	CA-1223	4LNB-249
L45	Coil, B.P.F (40MHz to 67.995MHz)	CA-1223	4LNB-249
L46	Coil, Choke 10 μ H	CA-9828	LAL03NA100K
L47	Not used		
L48	Coil, B.P.F (25MHz to 39.995MHz)	CA-8513	LAL03NAR33M
L49	Coil, B.P.F (25MHz to 39.995MHz)	CA-8513	LAL03NAR33M
L50	Coil, B.P.F (25MHz to 39.995MHz)	CA-8513	LAL03NAR33M
L51	Coil, B.P.F (25MHz to 39.995MHz)	CA-8513	LAL03NAR33M
L52	Coil, B.P.F (25MHz to 39.995MHz)	CA-8513	LAL03NAR33M
L53	Coil, B.P.F (25MHz to 39.995MHz)	CA-8513	LAL03NAR33M
L54	Not used		
L55	Coil, Trap (609.5MHz)	CA-1216	GR-H761
L56	Coil, D.B.M	CA-1224	2LNM-258
L57	Coil, D.B.M	CA-1224	2LNM-258
L58	Coil, Choke	SB-2119	2LNO-256
L59	Coil, 1st IF	CA-1217	GR-H763
L60	Coil, Trap (397.5MHz)	CA-1218	GR-H762
L61	Coil, Choke 0.68 μ H	CB-2116	LAL03NAR68M
L62	Coil, Choke 2.2mH	CB-2118	FL5HS222J-09
L63	Coil, Choke 1 μ H	CB-2117	LAL03NA1R0M
L64	Coil, Choke 100 μ H	CB-2070	LAL03NA101K
L65	Coil, Choke	CA-3182	3B037
L66	Stripline on P.C.B		
L67	Stripline on P.C.B		
L68	Stripline on P.C.B		
L69	Stripline on P.C.B		
L70	Stripline on P.C.B		
L71	Coil, Choke 1 μ H	CB-2117	LAL03NA1R0M
L301	Coil, Choke 10 μ H	CA-9828	LAL03NA100K
L302	Coil, Choke 10 μ H	CA-9828	LAL03NA100K
L303	Coil, Choke 10 μ H	CA-9828	LAL03NA100K
L304	Low-pass Filter	CA-1215	2.5LBN-257
L305	Low-pass Filter	CA-1215	2.5LNB-257
L306	Coil, Choke 10 μ H	CA-9828	LAL03NA100K
L307	Coil, Choke 10 μ H	CA-9828	LAL03NA100K

Ref. No.	Description	RS Part Number	MFR's Part Number
L308	Coil, Choke 0.33 μ H	CB-2120	FL3HR33K
L309	Coil, Choke	CB-2122	2LNO-254
L310	Coil, Choke 0.33 μ H	CB-2120	FL3HR33K
L311	Coil, Choke	CB-2123	2LNO-255
L312	Coil, Choke	CB-2124	2LNO-253
L313	Coil, Choke 100 μ H	CB-2070	LAL03NA101K
L314	Coil, Choke 100 μ H	CB-2070	LAL03NA101K
L315	Coil, Choke 100 μ H	CB-2070	LAL03NA101K
L316	Coil, Choke 100 μ H	CB-2070	LAL03NA101K
L317	Coil, Choke	CB-2124	2LNO-253
L318	Coil, Choke 10 μ H	CB-2071	FL3H100K
L319	Coil, Choke 100 μ H	CB-2070	LAL03NA101K
L320	Coil, Choke 100 μ H	CB-2070	LAL04NA101K
L321	Coil, Choke 1 μ H	CB-2117	LAL03NA1ROM
L322	Coil, Choke 1 μ H	CB-2117	LAL03NA1ROM
L323	Low-pass Filter, Stripline on P.C.B		
L324	Low-pass Filter, Stripline on P.C.B		
L325	Low-pass Filter, Stripline on P.C.B		
L326	Low-pass Filter, Stripline on P.C.B		
L327	High-pass Filter, Stripline on P.C.B		
L328	High-pass Filter, Stripline on P.C.B		
L329	High-pass Filter, Stripline on P.C.B		
L330	High-pass Filter, Stripline on P.C.B		
L501	Coil, Choke 100 μ H		LAL03KH101K
L502	Coil, Choke 100 μ H		LAL03KH101K
L503	Coil, Choke 100 μ H		LAL03KH101K
T1	Coil, 2nd IF	CA-1211	GR-N769
T2	Coil, 2nd IF (WFM Band)	CA-1212	GR-N764
T3	Coil, 2nd IF	CA-1212	GR-N764
T4	Coil, 3rd IF	CA-7246	GR-A470033
T5	Coil, 3rd IF	CA-7246	GR-A470033
T6	Coil, Quadrature DET. (WFM Band), 10.7MHz	CA-1213	GR-A793
T7	Coil, 3rd IF (AM Band)	CA-9882	GR-D681
T8	Coil, 3rd IF (AM Band)	CA-9883	GR-D682
T9	Coil, 2nd IF (AM, NFM Band)		GR-N797
T10	Coil, Filter		GR-N797
T11	Coil, 2nd IF (AM, NFM Band)		GR-N797
T12	Coil, 2nd IF (AM, NFM Band)	CA-1212	GR-N764
T13	Coil, Quadrature DET. (NFM Band)	CA-1214	GR-P792
T14	DC-DC Converter, Transformer	CA-1215	GE-84D-5242
T701	DC-AC Converter, Transformer	TB-0126	N19-5N75TK
△T801†	Transformer, Power	TA-0127	GE-85D-5667

† See Appendix (page 54) for ITI models.

TRANSISTORS

Ref. No.	Description	RS Part Number	MFR's Part Number
Q1	2SC2458(GR) (NPN) AGC. Cont.	2SC2458GR	2SC2458(GR)
Q2	2SC3356 (NPN)	2SC-3356	2SC3356
Q3	2SC3356 (NPN)	2SC-3356	2SC3356
Q4	2SC3356 (NPN)	2SC-3356	2SC3356
Q5	2SC3355 (NPN)	2SC-3355	2SC3355
Q6	2SC3355 (NPN)	2SC-3355	2SC3355
Q7	Not used		
Q8	2SC2458(GR) (NPN)	2SC2458GR	2SC2458(GR)

Ref. No.	Description	RS Part Number	MFR's Part Number
Q9	2SC2458(GR) (NPN)	2SC2458GR	2SC2458(GR)
Q10	2SC2458(GR) (NPN)	2SC2458GR	2SC2458(GR)
Q11	2SC2668(Y) (NPN)	2SC-2268	2SC2668(Y)
Q12	2SC2668(Y) (NPN)	2SC-2268	2SC2668(Y)
Q13	2SK192A(GR)	2SK-192AGR	2SK192A(GR)
Q14	2SC2458(Y) (NPN)	2SC-2458Y	2SC2458(Y)
Q15	2SC2458(GR) (NPN)	2SC-2458GR	2SC2458(GR)
Q16	2SC2458(Y) (NPN)	2SC-2458Y	2SC2458(Y)
Q17	2SC2458(Y) (NPN)	2SC-2458Y	2SC2458(Y)
Q18	2SC2668(Y) (NPN)	2SC-2668	2SC2668(Y)
Q19	2SC2668(Y) (NPN)	2SC-2668	2SC2668(Y)
Q20	2SA1048 (PNP)	2SA-1048	2SA1048
Q21	2SC2458(GR) (NPN)	2SC-2458GR	2SC2458(GR)
Q22	2SC2458L(GR) (NPN)	2SC-2458L	2SC2458L(GR)
Q23	2SC2458(GR) (NPN)	2SC-2458GR	2SC2458(GR)
Q24	2SC3327/2SD1330S (NPN)	2SC-3327	2SC3327/2SD1330S
Q25	2SC2458(GR) (NPN)	2SC-2458GR	2SC2458(GR)
Q26	2SC2458L(GR) (NPN)	2SC-2458L	2SC2458L(GR)
Q27	RN2005 (PNP) w/Resistor	1TR-0104	RN2005
Q28	RN2005 (PNP) w/Resistor	1TR-0104	RN2005
Q29	RN2005 (PNP) w/Resistor	1TR-0104	RN2005
Q30	2SC2458(GR) (NPN)	2SC-2458GR	2SC2458(GR)
Q31	2SC2458(GR) (NPN)	2SC-2458GR	2SC2458(GR)
Q32	2SD1406(GR) (NPN)	2SD-1406GR	2SD1406(GR)
Q33	2SC1815(GR) (NPN)	2SC-1815GR	2SC1815(GR)
Q34	2SC2458(GR) (NPN)	2SC-2458GR	2SC2458(GR)
Q301	RN2005 (PNP) w/Resistor	1TR-0104	RN2005
Q302	RN2005 (PNP) w/Resistor	1TR-0104	RN2005
Q303	2SC3358 (NPN)	2SC-3358	2SC3358
Q304	2SC3358 (NPN)	2SC-3358	2SC3358
Q305	2SC3358 (NPN)	2SC-3358	2SC3358
Q306	2SC3358 (NPN)	2SC-3358	2SC3358
Q307	2SC3358 (NPN)	2SC-3358	2SC3358
Q308	2SC3358 (NPN)	2SC-3358	2SC3358
Q309	2SC3358 (NPN)	2SC-3358	2SC3358
Q310	2SC3358 (NPN)	2SC-3358	2SC3358
Q311	2SC3358 (NPN)	2SC-3358	2SC3358
Q312	2SC3358 (NPN)	2SC-3358	2SC3358
Q313	2SC3358 (NPN)	2SC-3358	2SC3358
Q314	2SC3358 (NPN)	2SC-3358	2SC3358
Q315	RN2005 (PNP) w/Resistor	1TR-0104	RN2005
Q316	RN2005 (PNP) w/Resistor	1TR-0104	RN2005
Q317	Not used		
Q318	FET 2SK184(GR)	2SK-184GR	2SK184(GR)
Q319	2SC2458L(GR) (NPN)	2SC-2458L	2SC2458L(GR)
Q501	RN2201 (PNP) w/Resistor		RN2201
Q502	RN2201 (PNP) w/Resistor		RN2201
Q503	RN2201 (PNP) w/Resistor		RN2201
Q504	RN2201 (PNP) w/Resistor		RN2201
Q505	RN2201 (PNP) w/Resistor		RN2201
Q506	RN2201 (PNP) w/Resistor		RN2201
Q507	RN2201 (PNP) w/Resistor		RN2201
Q701	2SC945(QA) (NPN)		2SC945(QA)

RESISTORS

Ref. No.	Description				RS Part Number	MFR's Part Number
R1	Not used					
R2	Chip	100 ohm	1/8W	±5%	ND-0132EBN	ERJ-8GICYJ101
R3	Chip	82 ohm	1/8W	±5%	ND-0122EBN	ERJ-8GICYJ820
R4	Chip	100 ohm	1/8W	±5%	ND-0132EBN	ERJ-8GICYJ101
R5	Chip	100k ohm	1/8W	±5%	ND-0371EBN	ERJ-8GICYJ104
R6	Chip	10k ohm	1/8W	±5%	ND-0281EBN	ERJ-8GICYJ103
R7	Chip	3.3k ohm	1/8W	±5%	ND-0230EBN	ERJ-8GICYJ332
R8	Chip	470k ohm	1/8W	±5%	ND-0169EBN	ERJ-8GICYJ474
R9	Chip	470k ohm	1/8W	±5%	ND-0169EBN	ERJ-8GICYJ474
R10	Chip	1k ohm	1/8W	±5%	ND-0196EBN	ERJ-8GICYJ102
R11	Chip	47k ohm	1/8W	±5%	ND-0340EBN	ERJ-8GICYJ473
R12	Chip	4.7k ohm	1/8W	±5%	ND-0247EBN	ERJ-8GICYJ472
R13	Chip	1k ohm	1/8W	±5%	ND-0196EBN	ERJ-8GICYJ102
R14	Chip	470k ohm	1/8W	±5%	ND-0169EBN	ERJ-8GICYJ474
R15	Chip	470k ohm	1/8W	±5%	ND-0169EBN	ERJ-8GICYJ474
R16	Chip	100k ohm	1/8W	±5%	ND-0371EBN	ERJ-8GICYJ104
R17	Chip	3.3k ohm	1/8W	±5%	ND-0230EBN	ERJ-8GICYJ332
R18	Chip	470k ohm	1/8W	±5%	ND-0169EBN	ERJ-8GICYJ474
R19	Chip	470k ohm	1/8W	±5%	ND-0169EBN	ERJ-8GICYJ474
R20	Chip	470k ohm	1/8W	±5%	ND-0169EBN	ERJ-8GICYJ474
R21	Chip	1k ohm	1/8W	±5%	ND-0196EBN	ERJ-8GICYJ102
R22	Chip	4.7k ohm	1/8W	±5%	ND-0247EBN	ERJ-8GICYJ472
R23	Chip	1k ohm	1/8W	±5%	ND-0196EBN	ERJ-8GICYJ102
R24	Chip	470k ohm	1/8W	±5%	ND-0169EBN	ERJ-8GICYJ474
R25	Chip	470k ohm	1/8W	±5%	ND-0169EBN	ERJ-8GICYJ474
R26	Chip	470k ohm	1/8W	±5%	ND-0169EBN	ERJ-8GICYJ474
R27	Chip	470k ohm	1/8W	±5%	ND-0169EBN	ERJ-8GICYJ474
R28	Chip	470k ohm	1/8W	±5%	ND-0169EBN	ERJ-8GICYJ474
R29	Chip	470k ohm	1/8W	±5%	ND-0169EBN	ERJ-8GICYJ474
R30	Chip	470k ohm	1/8W	±5%	ND-0169EBN	ERJ-8GICYJ474
R31	Chip	1k ohm	1/8W	±5%	ND-0196EBN	ERJ-8GICYJ102
R32	Chip	4.7k ohm	1/8W	±5%	ND-0247EBN	ERJ-8GICYJ472
R33	Chip	1k ohm	1/8W	±5%	ND-0196EBN	ERJ-8GICYJ102
R34	Chip	470k ohm	1/8W	±5%	ND-0169EBN	ERJ-8GICYJ474
R35	Chip	470k ohm	1/8W	±5%	ND-0169EBN	ERJ-8GICYJ474
R36	Chip	470k ohm	1/8W	±5%	ND-0169EBN	ERJ-8GICYJ474
R37	Chip	470k ohm	1/8W	±5%	ND-0169EBN	ERJ-8GICYJ474
R38	Chip	1k ohm	1/8W	±5%	ND-0196EBN	ERJ-8GICYJ102
R39	Chip	4.7k ohm	1/8W	±5%	ND-0247EBN	ERJ-8GICYJ472
R40	Chip	1k ohm	1/8W	±5%	ND-0196EBN	ERJ-8GICYJ102
R41	Chip	470k ohm	1/8W	±5%	ND-0169EBN	ERJ-8GICYJ474
R42	Chip	470k ohm	1/8W	±5%	ND-0169EBN	ERJ-8GICYJ474
R43	Chip	1k ohm	1/8W	±5%	ND-0196EBN	ERJ-8GICYJ102
R44	Chip	4.7k ohm	1/8W	±5%	ND-0247EBN	ERJ-8GICYJ472
R45	Chip	1k ohm	1/8W	±5%	ND-0196EBN	ERJ-8GICYJ102
R46	Chip	1k ohm	1/8W	±5%	ND-0196EBN	ERJ-8GICYJ102
R47	Chip	4.7k ohm	1/8W	±5%	ND-0247EBN	ERJ-8GICYJ472
R48	Chip	1k ohm	1/8W	±5%	ND-0196EBN	ERJ-8GICYJ102
R49	Chip	1k ohm	1/8W	±5%	ND-0196EBN	ERJ-8GICYJ102
R50	Chip	4.7k ohm	1/8W	±5%	ND-0247EBN	ERJ-8GICYJ472
R51	Chip	1k ohm	1/8W	±5%	ND-0196EBN	ERJ-8GICYJ102
R52	Chip	1k ohm	1/8W	±5%	ND-0196EBN	ERJ-8GICYJ102
R53	Chip	270 ohm	1/8W	±5%	ND-0155EBN	ERJ-8GICYJ271
R54	Chip	2.2k ohm	1/8W	±5%	ND-0216EBN	ERJ-8GICYJ222
R55	Chip	470 ohm	1/8W	±5%	ND-0169EBN	ERJ-8GICYJ471

Ref. No.	Description				RS Part Number	MFR's Part Number
R56	Chip	22 ohm	1/8W	±5%	ND-0078EBN	ERJ-8GCVJ220
R57	Chip	820 ohm	1/8W	±5%	ND-0187EBN	ERJ-8GCVJ821
R58	Chip	1k ohm	1/8W	±5%	ND-0196EBN	ERJ-8GCVJ102
R59	Chip	680 ohm	1/8W	±5%	ND-0183EBN	ERJ-8GCVJ681
R60	Chip	330 ohm	1/8W	±5%	ND-0159EBN	ERJ-8GCVJ331
R61	Chip	56 ohm	1/8W	±5%	ND-0107EBN	ERJ-8GCVJ560
R62	Chip	680 ohm	1/8W	±5%	ND-0183EBN	ERJ-8GCVJ681
R63	Chip	1k ohm	1/8W	±5%	ND-0196EBN	ERJ-8GCVJ102
R64	Chip	470 ohm	1/8W	±5%	ND-0169EBN	ERJ-8GCVJ471
R65	Chip	100 ohm	1/8W	±5%	ND-0132EBN	ERJ-8GCVJ101
R66	Chip	47 ohm	1/8W	±5%	ND-0099EBN	ERJ-8GCVJ470
R67	Chip	56 ohm	1/8W	±5%	ND-0107EBN	ERJ-8GCVJ560
R68	Chip	1.5k ohm	1/8W	±5%	ND-0206EBN	ERJ-8GCVJ152
R69	Chip	2.2k ohm	1/8W	±5%	ND-0216EBN	ERJ-8GCVJ222
R70	Chip	330 ohm	1/8W	±5%	ND-0159EBN	ERJ-8GCVJ331
R71	Chip	100 ohm	1/8W	±5%	ND-0132EBN	ERJ-8GCVJ101
R72	Chip	56 ohm	1/8W	±5%	ND-0107EBN	ERJ-8GCVJ560
R73	Chip	47k ohm	1/8W	±5%	ND-0340EBN	ERJ-8GCVJ473
R74	Chip	220k ohm	1/8W	±5%	ND-0396EBN	ERJ-8GCVJ224
R75	Chip	56 ohm	1/8W	±5%	ND-0107EBN	ERJ-8GCVJ560
R76	Chip	330 ohm	1/8W	±5%	ND-0159EBN	ERJ-8GCVJ331
R77	Chip	47 ohm	1/8W	±5%	ND-0099EBN	ERJ-8GCVJ470
R78	Chip	220 ohm	1/8W	±5%	ND-0149EBN	ERJ-8GCVJ221
R79	Carbon film	1k ohm	1/6W	±5%	N-0196ECC	RD16U102J
R80	Chip	56 ohm	1/8W	±5%	ND-0107EBN	ERJ-8GCVJ560
R81	Carbon film	100k ohm	1/6W	±5%	N-0371ECC	RD16U104J
R82	Carbon film	47k ohm	1/6W	±5%	N-0340ECC	RD16U473J
R83	Carbon film	120k ohm	1/6W	±5%	N-0375ECC	RD16U124J
R84	Carbon film	15k ohm	1/6W	±5%	N-0297ECC	RD16U153J
R85	Carbon film	47k ohm	1/6W	±5%	N-0340ECC	RD16U473J
R86	Carbon film	10k ohm	1/6W	±5%	N-0281ECC	RD16U103J
R87	Carbon film	27k ohm	1/6W	±5%	N-0316ECC	RD16U273J
R88	Carbon film	56k ohm	1/6W	±5%	N-0345ECC	RD16U563J
R89	Carbon film	5.6k ohm	1/6W	±5%	N-0257ECC	RD16U562J
R90	Carbon film	2.2k ohm	1/6W	±5%	N-0216ECC	RD16U222J
R91	Carbon film	47k ohm	1/6W	±5%	N-0340ECC	RD16U473J
R92	Carbon film	47k ohm	1/6W	±5%	N-0340ECC	RD16U473J
R93	Carbon film	220k ohm	1/6W	±5%	N-0396ECC	RD16U224J
R94	Carbon film	1k ohm	1/6W	±5%	N-0196ECC	RD16U102J
R95	Carbon film	1k ohm	1/6W	±5%	N-0196ECC	RD16U102J
R96	Carbon film	100k ohm	1/6W	±5%	N-0371ECC	RD16U104J
R97	Carbon film	220 ohm	1/6W	±5%	N-0149ECC	RD16U221J
R98	Carbon film	10k ohm	1/6W	±5%	N-0281ECC	RD16U103J
R99	Carbon film	1k ohm	1/6W	±5%	N-0196ECC	RD16U102J
R100	Carbon film	1k ohm	1/6W	±5%	N-0196ECC	RD16U102J
R101	Carbon film	6.8k ohm	1/6W	±5%	N-0262ECC	RD16U682J
R102	Carbon film	2.2k ohm	1/6W	±5%	N-0216ECC	RD16U222J
R103	Carbon film	1k ohm	1/6W	±5%	N-0196ECC	RD16U102J
R104	Carbon film	220k ohm	1/6W	±5%	N-0396ECC	RD16U224J
R105	Carbon film	220 ohm	1/6W	±5%	N-0149ECC	RD16S221J
R106	Carbon film	10 ohm	1/6W	±5%	N-0063ECC	RD16U100J
R107	Carbon film	330 ohm	1/6W	±5%	N-0159ECC	RD16U331J
R108	Carbon film	120 ohm	1/6W	±5%	N-0136ECC	RD16U121J
R109	Carbon film	33k ohm	1/6W	±5%	N-0324ECC	RD16U333J
R110	Carbon film	33k ohm	1/6W	±5%	N-0324ECC	RD16U333J
R111	Not used					
R112	Carbon film	1M ohm	1/6W	±5%	N-0445ECC	RD16U105J

Ref. No.	Descriptoin				RS Part Number	MFR's Part Number
R113	Carbon film	1k ohm	1/6W	±5%	N-0196ECC	RD16U102J
R114	Carbon film	22k ohm	1/6W	±5%	N-0311ECC	RD16U223J
R115	Carbon film	470 ohm	1/6W	±5%	N-0169ECC	RD16U471J
R116	Carbon film	270k ohm	1/6W	±5%	N-0402ECC	RD16U274J
R117	Carbon film	15k ohm	1/6W	±5%	N-0297ECC	RD16S153J
R118	Carbon film	470 ohm	1/6W	±5%	N-0169ECC	RD16U471J
R119	Carbon film	100 ohm	1/6W	±5%	N-0132ECC	RD16U101J
R120	Carbon film	180k ohm	1/6W	±5%	N-0387ECC	RD16U184J
R121	Carbon film	33k ohm	1/6W	±5%	N-0324ECC	RD16U333J
R122	Carbon film	100 ohm	1/6W	±5%	N-0132ECC	RD16U101J
R123	Carbon film	10k ohm	1/6W	±5%	N-0281ECC	RD16U103J
R124	Carbon film	4.7k ohm	1/6W	±5%	N-0247ECC	RD16U472J
R125	Carbon film	220k ohm	1/6W	±5%	N-0396ECC	RD16U224J
R126	Carbon film	10k ohm	1/6W	±5%	N-0281ECC	RD16U103J
R127	Carbon film	10k ohm	1/6W	±5%	N-0281ECC	RD16U103J
R128	Carbon film	10k ohm	1/6W	±5%	N-0281ECC	RD16U103J
R129	Carbon film	2.2k ohm	1/6W	±5%	N-0216ECC	RD16U222J
R130	Carbon film	390k ohm	1/6W	±5%	N-0414ECC	RD16S394J
R131	Carbon film	3.3k ohm	1/6W	±5%	N-0230ECC	RD16S332J
R132	Carbon film	470 ohm	1/6W	±5%	N-0169ECC	RD16U471J
R133	Carbon film	1k ohm	1/6W	±5%	N-0196ECC	RD16U102J
R134	Carbon film	1k ohm	1/6W	±5%	N-0196ECC	RD16U102J
R135	Carbon film	390k ohm	1/6W	±5%	N-0414ECC	RD16S394J
R136	Carbon film	5.6k ohm	1/6W	±5%	N-0257ECC	RD16S562J
R137	Carbon film	100 ohm	1/6W	±5%	N-0132ECC	RD16U101J
R138	Carbon film	100 ohm	1/6W	±5%	N-0132ECC	RD16U101J
R139	Carbon film	100 ohm	1/6W	±5%	N-0132ECC	RD16S101J
R140	Carbon film	33k ohm	1/6W	±5%	N-0324ECC	RD16S333J
R141	Carbon film	1.5k ohm	1/6W	±5%	N-0206ECC	RD16U152J
R142	Carbon film	3.3k ohm	1/6W	±5%	N-0230ECC	RD16U332J
R143	Carbon film	1.5k ohm	1/6W	±5%	N-0206ECC	RD16U152J
R144	Carbon film	100k ohm	1/6W	±5%	N-0371ECC	RD16U104J
R145	Carbon film	33k ohm	1/6W	±5%	N-0324ECC	RD16U333J
R146	Carbon film	47k ohm	1/6W	±5%	N-0340ECC	RD16U473J
R147	Carbon film	33k ohm	1/6W	±5%	N-0324ECC	RD16U333J
R148	Carbon film	47k ohm	1/6W	±5%	N-0340ECC	RD16U473J
R149	Carbon film	2.2k ohm	1/6W	±5%	N-0216ECC	RD16U222J
R150	Carbon film	100k ohm	1/6W	±5%	N-0371ECC	RD16U104J
R151	Carbon film	4.7k ohm	1/6W	±5%	N-0247ECC	RD16U472J
R152	Carbon film	1M ohm	1/6W	±5%	N-0445ECC	RD16U105J
R153	Carbon film	10k ohm	1/6W	±5%	N-0281ECC	RD16U103J
R154	Carbon film	10k ohm	1/6W	±5%	N-0281ECC	RD16U103J
R155	Carbon film	4.7k ohm	1/6W	±5%	N-0247ECC	RD16U472J
R156	Carbon film	10k ohm	1/6W	±5%	N-0281ECC	RD16U103J
R157	Carbon film	8.2k ohm	1/6W	±5%	N-0271ECC	RD16U822J
R158	Carbon film	1.5k ohm	1/6W	±5%	N-0206ECC	RD16U152J
R159	Carbon film	2.7k ohm	1/6W	±5%	N-0224ECC	RD16U272J
R160	Carbon film	1k ohm	1/6W	±5%	N-0196ECC	RD16U102J
R161	Carbon film	4.7k ohm	1/6W	±5%	N-0247ECC	RD16U472J
R162	Carbon film	3.3k ohm	1/6W	±5%	N-0230ECC	RD16U332J
R163	Carbon film	4.7k ohm	1/6W	±5%	N-0247ECC	RD16U472J
R164	Carbon film	2.7k ohm	1/6W	±5%	N-0224ECC	RD16U272J
R165	Carbon film	33k ohm	1/6W	±5%	N-0324ECC	RD16U333J
R166	Carbon film	47k ohm	1/6W	±5%	N-0340ECC	RD16U473J
R167	Carbon film	100k ohm	1/6W	±5%	N-0371ECC	RD16U104J
R168	Carbon film	5.6k ohm	1/6W	±5%	N-0257ECC	RD16U562J
R169	Carbon film	10k ohm	1/6W	±5%	N-0281ECC	RD16U103J

Ref. No.	Description				RS Part Number	MFR's Part Number
R170	Carbon film	100k ohm	1/6W	±5%	N-0371ECC	RD16U104J
R171	Carbon film	10k ohm	1/6W	±5%	N-0281ECC	RD16U103J
R172	Carbon film	33k ohm	1/6W	±5%	N-0324ECC	RD16U333J
R173	Carbon film	10k ohm	1/6W	±5%	N-0281ECC	RD16U103J
R174	Carbon film	10k ohm	1/6W	±5%	N-0281ECC	RD16U103J
R175	Carbon film	33k ohm	1/6W	±5%	N-0324ECC	RD16U333J
R176	Carbon film	33k ohm	1/6W	±5%	N-0324ECC	RD16U333J
R177	Carbon film	4.7k ohm	1/6W	±5%	N-0247ECC	RD16U472J
R178	Carbon film	1M ohm	1/6W	±5%	N-0445ECC	RD16U105J
R179	Carbon film	1.5k ohm	1/6W	±5%	N-0206ECC	RD16U152J
R180	Carbon film	4.7k ohm	1/6W	±5%	N-0247ECC	RD16U472J
R181	Carbon film	100k ohm	1/6W	±5%	N-0371ECC	RD16U104J
R182	Carbon film	4.7k ohm	1/6W	±5%	N-0247ECC	RD16U472J
R183	Carbon film	220k ohm	1/6W	±5%	N-0396ECC	RD16U224J
R184	Carbon film	47k ohm	1/6W	±5%	N-0340ECC	RD16U473J
R185	Carbon film	47k ohm	1/6W	±5%	N-0340ECC	RD16U473J
R186	Carbon film	10k ohm	1/6W	±5%	N-0281ECC	RD16U103J
R187	Carbon film	10k ohm	1/6W	±5%	N-0281ECC	RD16U103J
R188	Carbon film	100k ohm	1/6W	±5%	N-0371ECC	RD16U104J
R189	Carbon film	10k ohm	1/6W	±5%	N-0281ECC	RD16U103J
R190	Carbon film	15k ohm	1/6W	±5%	N-0297ECC	RD16U153J
R191	Carbon film	68k ohm	1/6W	±5%	N-0354ECC	RD16U683J
R192	Carbon film	100k ohm	1/6W	±5%	N-0371ECC	RD16U104J
R193	Carbon film	100k ohm	1/6W	±5%	N-0371ECC	RD16U104J
R194	Carbon film	10k ohm	1/6W	±5%	N-0281ECC	RD16U103J
R195	Carbon film	22k ohm	1/6W	±5%	N-0311ECC	RD16U223J
R196	Carbon film	10k ohm	1/6W	±5%	N-0281ECC	RD16U103J
R197	Carbon film	100k ohm	1/6W	±5%	N-0371ECC	RD16U104J
R198	Carbon film	10k ohm	1/6W	±5%	N-0281ECC	RD16U103J
R199	Carbon film	82k ohm	1/6W	±5%	N-0360ECC	RD16U823J
R200	Carbon film	10k ohm	1/6W	±5%	N-0281ECC	RD16U103J
R201	Carbon film	47k ohm	1/6W	±5%	N-0340ECC	RD16U473J
R202	Carbon film	22k ohm	1/6W	±5%	N-0311ECC	RD16U223J
R203	Carbon film	22k ohm	1/6W	±5%	N-0311ECC	RD16U223J
R204	Carbon film	47k ohm	1/6W	±5%	N-0340ECC	RD16U473J
R205	Carbon film	22k ohm	1/6W	±5%	N-0311ECC	RD16U223J
R206	Carbon film	47k ohm	1/6W	±5%	N-0340ECC	RD16U473J
R207	Carbon film	1M ohm	1/6W	±5%	N-0445ECC	RD16U105J
R208	Carbon film	2.7k ohm	1/6W	±5%	N-0224ECC	RD16U272J
R209	Carbon film	470 ohm	1/6W	±5%	N-0169ECC	RD16U471J
R210	Carbon film	22k ohm	1/6W	±5%	N-0311ECC	RD16U223J
R211	Carbon film	100k ohm	1/6W	±5%	N-0371ECC	RD16U104J
R212	Carbon film	1M ohm	1/6W	±5%	N-0445ECC	RD16U105J
R213	Carbon film	1k ohm	1/6W	±5%	N-0196ECC	RD16U102J
R214†	Metal film	3.3 ohm	1W	±5%	N-0037EGE	RNS1.0-3R3J
R215	Carbon film	10k ohm	1/6W	±5%	N-0281ECC	RD16S103J
R216	Carbon film	47 ohm	1/6W	±5%	N-0099ECC	RD16S470J
R217	Carbon film	1 ohm	1/6W	±5%	N-0022ECC	RD16U010J
R218	Carbon film	270 ohm	1/6W	±5%	N-0155ECC	RD16U271J
R219	Carbon film	56k ohm	1/6W	±5%	N-0345ECC	RD16U563J
R220	Carbon film	33k ohm	1/6W	±5%	N-0324ECC	RD16U333J
R221	Carbon film	470k ohm	1/6W	±5%	N-0423ECC	RD16U474J
R222	Carbon film	180k ohm	1/6W	±5%	N-0387ECC	RD16U184J
R223	Carbon film	2.2M ohm	1/6W	±5%	N-0454ECC	RD16U225J
R224	Carbon film	2.2M ohm	1/6W	±5%	N-0454ECC	RD16U225J
R225	Carbon film	10k ohm	1/6W	±5%	N-0281ECC	RD16U103J
R226	Carbon film	330 ohm	1/6W	±5%	N-0159ECC	RD16U331J

† See Appendix (page 54) for ITI models.

Ref. No.	Description				RS Part Number	MFR's Part Number
R227	Carbon film	220 ohm	1/6W	±5%	N-0149ECC	RD16U221J
R228	Carbon film	100k ohm	1/6W	±5%	N-0371ECC	RD16U104J
R229	Carbon film	15k ohm	1/6W	±5%	N-0297ECC	RD16U153J
R230	Carbon film	33k ohm	1/6W	±5%	N-0324ECC	RD16S333J
R231	Carbon film	220k ohm	1/6W	±5%	N-0396ECC	RD16U224J
R232	Carbon film	15k ohm	1/6W	±5%	N-0297ECC	RD16U153J
R233	Carbon film	33k ohm	1/6W	±5%	N-0324ECC	RD16U333J
R234	Carbon film	5.6k ohm	1/6W	±5%	N-0257ECC	RD16U562J
R235†	Metal film	1 ohm	1W	±5%	N-0022EGE	RNS1.0-010J
R236	Chip	3.3k ohm	1/8W	±5%	ND-0230EBN	ERJ-8GCYJ332
R237	Carbon film	100 ohm	1/6W	±5%	N-0132ECC	RD16U101J
R238	Carbon film	4.7k ohm	1/6W	±5%	N-0247ECC	RD16U472J
R239	Carbon film	10k ohm	1/6W	±5%	N-0281ECC	RD16U103J
R240	Carbon film	4.7k ohm	1/6W	±5%	N-0247ECC	RD16U472J
R241	Chip	4.7k ohm	1/8W	±5%	ND-0247EBN	ERJ-8GCYJ472
R242	Chip	10k ohm	1/8W	±5%	ND-0281EBN	ERJ-8GCYJ103
R243	Chip	4.7k ohm	1/8W	±5%	ND-0247EBN	ERJ-8GCYJ472
R244	Carbon film	220k ohm	1/6W	±5%	N-0396ECC	RD16U224J
R245	Carbon film	180k ohm	1/6W	±5%	N-0387ECC	RD16U184J
R246	Carbon film	4.7k ohm	1/6W	±5%	N-0247ECC	RD16U472J
R247	Carbon film	10k ohm	1/6W	±5%	N-0281ECC	RD16U103J
R248	Carbon film	220 ohm	1/4W	±5%		ERD-25PJ221
R249	Carbon film	220 ohm	1/4W	±5%		ERD-25PJ221
R250	Carbon film	220 ohm	1/4W	±5%		ERD-25PJ221
R251	Carbon film	220 ohm	1/4W	±5%		ERD-25PJ221
R252	Carbon film	220 ohm	1/4W	±5%		ERD-25PJ221
R253	Carbon film	220 ohm	1/4W	±5%		ERD-25PJ221
R254	Carbon film	220 ohm	1/4W	±5%		ERD-25PJ221
R255	Chip	100 ohm	1/8W	±5%	ND-0132EBN	ERJ-8GCYJ101
R256	Carbon film	1 ohm	1/2W	±5%	N-0022EFE	RNF1/2S1R0J
R301	Carbon film	2.2k ohm	1/6W	±5%	N-0216ECC	RD16U222J
R302	Carbon film	100 ohm	1/6W	±5%	N-0132ECC	RD16U101J
R303	Carbon film	220 ohm	1/6W	±5%	N-0149ECC	RD16U221J
R304	Carbon film	47k ohm	1/6W	±5%	N-0340ECC	RD16U473J
R305	Carbon film	2.2k ohm	1/6W	±5%	N-0216ECC	RD16U222J
R306	Carbon film	1k ohm	1/6W	±5%	N-0196ECC	RD16U102J
R307	Carbon film	100 ohm	1/6W	±5%	N-0132ECC	RD16U101J
R308	Carbon film	220 ohm	1/6W	±5%	N-0149ECC	RD16U221J
R309	Carbon film	100k ohm	1/6W	±5%	N-0371ECC	RD16U104J
R310	Carbon film	10 ohm	1/6W	±5%	N-0063ECC	RD16U100J
R311	Carbon film	100 ohm	1/6W	±5%	N-0132ECC	RD16U101J
R312	Carbon film	33k ohm	1/6W	±5%	N-0324ECC	RD16U333J
R313	Carbon film	100 ohm	1/6W	±5%	N-0132ECC	RD16U101J
R314	Carbon film	10 ohm	1/6W	±5%	N-0063ECC	RD16U100J
R315	Carbon film	47k ohm	1/6W	±5%	N-0340ECC	RD16U473J
R316	Carbon film	1k ohm	1/6W	±5%	N-0196ECC	RD16U102J
R317	Carbon film	100 ohm	1/6W	±5%	N-0132ECC	RD16U101J
R318	Carbon film	220 ohm	1/6W	±5%	N-0149ECC	RD16U221J
R319	Carbon film	47k ohm	1/6W	±5%	N-0340ECC	RD16U473J
R320	Carbon film	220 ohm	1/6W	±5%	N-0149ECC	RD16U221J
R321	Carbon film	100 ohm	1/6W	±5%	N-0132ECC	RD16U101J
R322	Carbon film	100k ohm	1/6W	±5%	N-0371ECC	RD16U104J
R323	Carbon film	100 ohm	1/6W	±5%	N-0132ECC	RD16U101J
R324	Carbon film	47k ohm	1/6W	±5%	N-0340ECC	RD16U473J
R325	Carbon film	220 ohm	1/6W	±5%	N-0149ECC	RD16U221J
R326	Carbon film	100 ohm	1/6W	±5%	N-0132ECC	RD16U101J
R327	Carbon film	220 ohm	1/6W	±5%	N-0149ECC	RD16U221J

† See Appendix (page 54) for ITI models.

Ref. No.	Description				RS Part Number	MFR's Part Number
R328	Carbon film	47k ohm	1/6W	±5%	N-0340ECC	RD16U473J
R329	Chip	1k ohm	1/8W	±5%	ND-0196EBN	ERJ-8GICYJ102
R330	Carbon film	470 ohm	1/6W	±5%	N-0169ECC	RD16U471J
R331	Carbon film	220 ohm	1/6W	±5%	N-0149ECC	RD16U221J
R332	Chip	2.2k ohm	1/8W	±5%	ND-0216EBN	ERJ-8GICYJ222
R333	Chip	4.7k ohm	1/8W	±5%	ND-0247EBN	ERJ-8GICYJ472
R334	Chip	100k ohm	1/8W	±5%	ND-0371EBN	ERJ-8GICYJ104
R335	Carbon film	10k ohm	1/6W	±5%	N-0281ECC	RD16U103J
R336	Carbon film	220 ohm	1/6W	±5%	N-0149ECC	RD16U221J
R337	Chip	1k ohm	1/8W	±5%	ND-0196EBN	ERJ-8GICYJ102
R338	Carbon film	470 ohm	1/6W	±5%	N-0169ECC	RD16U471J
R339	Chip	2.2k ohm	1/8W	±5%	ND-0216EBN	ERJ-8GICYJ222
R340	Chip	4.7k ohm	1/8W	±5%	ND-0247EBN	ERJ-8GICYJ472
R341	Chip	100k ohm	1/8W	±5%	ND-0371EBN	ERJ-8 GICYJ104
R342	Carbon film	10k ohm	1/6W	±5%	N-0281ECC	RD16U103J
R343	Carbon film	1k ohm	1/6W	±5%	N-0196ECC	RD16U102J
R344	Not used					
R345	Carbon film	470 ohm	1/6W	±5%	N-0169ECC	RD16U471J
R346	Carbon film	100 ohm	1/6W	±5%	N-0132ECC	RD16U101J
R347	Carbon film	8.2k ohm	1/6W	±5%	N-0271ECC	RD16U822J
R348	Carbon film	330 ohm	1/6W	±5%	N-0159ECC	RD16U331J
R349	Carbon film	4.7k ohm	1/6W	±5%	N-0247ECC	RD16U472J
R350	Carbon film	100 ohm	1/6W	±5%	N-0132ECC	RD16U101J
R351	Carbon film	100 ohm	1/6W	±5%	N-0132ECC	RD16U101J
R352	Chip	15k ohm	1/8W	±5%	ND-0297EBN	ERJ-8GICYJ153
R353	Carbon film	470 ohm	1/6W	±5%	N-0169ECC	RD16U471J
R354	Chip	4.7k ohm	1/8W	±5%	ND-0247EBN	ERJ-8GICYJ472
R355	Carbon film	33k ohm	1/6W	±5%	N-0324ECC	RD16U333J
R356	Carbon film	4.7k ohm	1/6W	±5%	N-0247ECC	RD16U472J
R357	Carbon film	2.2k ohm	1/6W	±5%	N-0216ECC	RD16U222J
R358	Carbon film	2.2k ohm	1/6W	±5%	N-0216ECC	RD16U222J
R359	Not used					
R360	Carbon film	5.6k ohm	1/6W	±5%	N-0257ECC	RD16U562J
R361	Not used					
R362	Not used					
R363	Not used					
R364	Carbon film	1k ohm	1/6W	±5%	N-0196ECC	RD16U102J
R365	Carbon film	15k ohm	1/6W	±5%	N-0297ECC	RD16U153J
R366	Carbon film	10k ohm	1/6W	±5%	N-0281ECC	RD16U103J
R367	Carbon film	1k ohm	1/6W	±5%	N-0196ECC	RD16U102J
R368	Carbon film	100 ohm	1/6W	±5%	N-0132ECC	RD16U101J
R369	Carbon film	2.2k ohm	1/6W	±5%	N-0216ECC	RD16U222J
R370	Carbon film	820 ohm	1/6W	±5%		RD16U821J
R371	Carbon film	1k ohm	1/6W	±5%	N-0196ECC	RD16U102J
R501	Carbon film	100k ohm	1/6W	±5%	N-0371ECC	RD16U104J
R502	Carbon film	1M ohm	1/6W	±5%	N-0445ECC	RD16U105J
R503	Carbon film	10k ohm	1/6W	±5%	N-0281ECC	RD16U103J
R504	Carbon film	10k ohm	1/6W	±5%	N-0281ECC	RD16U103J
R505	Carbon film	10k ohm	1/6W	±5%	N-0281ECC	RD16U103J
R506	Carbon film	10k ohm	1/6W	±5%	N-0281ECC	RD16U103J
R507	Carbon film	10k ohm	1/6W	±5%	N-0281ECC	RD16U103J
R508	Carbon film	10k ohm	1/6W	±5%	N-0281ECC	RD16U103J
R509	Carbon film	10k ohm	1/6W	±5%	N-0281ECC	RD16U103J
R510	Carbon film	10k ohm	1/6W	±5%	N-0281ECC	RD16U103J
R511	Carbon film	10k ohm	1/6W	±5%	N-0281ECC	RD16U103J
R512	Carbon film	10k ohm	1/6W	±5%	N-0281ECC	RD16U103J
R513	Carbon film	10k ohm	1/6W	±5%	N-0281ECC	RD16U103J

Ref. No.	Description	RS Part Number	MFR's Part Number
R514	Carbon film 47k ohm 1/6W ±5%	N-0340ECC	RD16U473J
R515	Carbon film 10k ohm 1/6W ±5%	N-0281ECC	RD16U103J
R516	Carbon film 560k ohm 1/6W ±5%		RD16U564J
R517	Carbon film 10k ohm 1/6W ±5%	N-0281ECC	RD16U103J
R518	Carbon film 47k ohm 1/6W ±5%	N-0340ECC	RD16U473J
R519	Carbon film 47k ohm 1/6W ±5%	N-0340ECC	RD16U473J
R520	Carbon film 47k ohm 1/6W ±5%	N-0340ECC	RD16U473J
R521	Carbon film 47k ohm 1/6W ±5%	N-0340ECC	RD16U473J
R522	Carbon film 47k ohm 1/6W ±5%	N-0340ECC	RD16U473J
R701	Carbon film 4.7k ohm 1/6W ±5%	N-0247ECC	RD16U472J
R702	Carbon film 100 ohm 1/6W ±5%	N-0132ECC	RD16U101J
R703	Carbon film 10 ohm 1/6W ±5%	N-0063ECC	RD16U100J
R704	Carbon film 1.2k ohm 1/6W ±5%		RD16U122J
R705	Carbon film 10k ohm 1/6W ±5%	N-0281ECC	RD16U103J
R706	Carbon film 10k ohm 1/6W ±5%	N-0281ECC	RD16U103J
R707	Carbon film 10k ohm 1/6W ±5%	N-0281ECC	RD16U103J
R708	Carbon film 180k ohm 1/6W ±5%	N-0387ECC	RD16U184J
R709	Carbon film 22 ohm 1/6W ±5%		RD16U220J
R710	Carbon film 150 ohm 1/6W ±5%		RD16U151J
R711	Carbon film 6.8k ohm 1/6W ±5%	N-0262ECC	RD16U682J
R801†	Solid 1.8M ohm 1/2W ±10%	N-0521FFB	ERC-12GK185

† See Appendix (page 54) for ITI models.

CRYSTALS & FILTERS			
Ref. No.	Description	RS Part Number	MFR's Part Number
X1	Crystal TC-43 type 37.8 MHz	CX-0551	37.8 MHz
X2	Crystal TC-43 type 48.045 MHz	CX-0552	48.045 MHz
X301	Crystal TX1824G-3 type 10 MHz	CX-0480	10 MHz
CX501	Ceramic Oscillator 7.37 MHz		CST7.37MT
XF1	Crystal Filter MF48RB type 48.5 MHz	C-1923	48.5 MHz
XF2	Crystal Filter MF48RB type 48.5 MHz	C-1923	48.5 MHz
CF1	Ceramic Filter 10.7 MHz	C-1924	SFJ10.7 MA2-A
CF2	Ceramic Filter 455 kHz	C-1044	CFW455D

VARIABLE RESISTORS			
Ref. No.	Description	RS Part Number	MFR's Part Number
VR801	Pot. Volume w/Switch 50k ohm (A)	P-7787	5M1411-50KA-20A
VR802	Pot. Squelch 10k ohm (C)	P-8029	K1611008TE-10KC-20

MISCELLANEOUS

Ref. No.	Description	RS Part Number	MFR's Part Number
CN-1	Pin, connector 3 Pin Male	J-5678	PI22A03M
CN-2	Pin, connector 4 Pin Male	J-4050	PI22A04M
CN-3	Pin, connector 2 Pin Male	J-4051	PI22A02M
CN-4	Pin, connector 3 Pin Male	J-5678	PI22A03M
CN-5	Pin, connector 2 Pin Male	J-4051	PI22A02M
CN-6	Pin, connector 3 Pin Male	J-5678	PI22A03M
CN-501	Pin, connector 9 Pin Male		PI22A09M
CN-502	Pin, connector 13 Pin Male		PI22A13M
CN-503	Pin, connector 8 Pin Male		PI22A08M
CN-504	Pin, connector 15 Pin Male		PI22A15M
CN-505	Pin, connector 11 Pin Male		PI22A11M
EL701	Electro Luminescence	L-2082	GE-85D-6011
J1	Jack	J-5939	TMP-J01X-V1
J2	Jack	J-5939	TMP-J01X-V1
J3	Jack, Tape Out	J-1820	JPJ0573-01-010
J4	Jack Ext. Speaker	J-1821	S-G8036
J5	Jack, DC	J-1140	HEC0470-01-630
J6	Jack, Antenna	J-0085	GE-85D-5383
J801	Jack, Head Phone	J-1824	S-G8022#2
LCD701	LCD		FTD-8200P
SW1	Switch, slide (Attenuator)	S-3627	SSFZUB22-07
SW501	Switch, push (Reset)		SKHHLM
SW701	Switch, push (Sound Squelch)	S-7094	ESB-64500 type 1
SW702	Switch, push (Dimmer)	S-7094	ESB-64500 type 1
TH-1	Thermister	T-1024	HT-100
TP1	Pin, test		ERD-25TC0
TP2	Pin, test		ERD-25TC0
TP3	Pin, test		ERD-25TC0
TP4	Pin, test		ERD-25TC0
TP5	Pin, test		ERD-25TC0
TP301	Pin, test		ERD-25TC0
TP302	Pin, test		ERD-25TC0
	Antenna, rod		GE-86D-6519
	Binder, AC cord		NO.5121/W-140
	Binder, cord		PLT1M-M/BK-1
	Cord, AC 6.5 feet (UL)		GE-86D-6312
	Foot		OK15
SP801	Snap, battery w/cable 1 type, L=250mm	B-0209	
	Speaker	SP-5374	SM-77KY-2
	Strainrelief, Line Cord	HB-0705	SR-3P-4
	Switch, push	S-7093	SKHHPK
	Terminal, solderless	HB-9616	1-SD
	Wire Kit		#327(A)

MECHANICAL PARTS LIST

Ref. No.	Description	RS Part Number	MFR's Part Number
1	Cabinet	Z-1484	GE-86B-6360
2	Chassis		GE-86A-6359
3	PCB Ass'y, Linear		GA-86D-6316
4	Bracket, Antenna Connector		GE-86D-6362
5 J6	Jack, Antenna	J-0085	GE-85D-5383
6	Shield, Antenna		GE-86D-6381
7	Case, IF Shield		GE-86D-6377
8	Case, BPF Shield		GE-86D-6379
9	Top, IF Shield		GE-86D-6378
10	Top, BPF Shield		GE-86D-6380
11	Plate, 1st IF Shield		GE-86D-6605
12	Heat Sink		GE-86D-6363
13	PCB Ass'y, PLL		GA-86D-6317
14	Bottom PLL Shield (A) Filter		GE-86D-6511
15	Bottom PLL Shield (A) VCO		GE-86D-6510
16	Bottom PLL Shield (B) IC		GE-86D-6513
17	Bottom PLL Shield (B) VCO		GE-86D-6512
18	Fiber, PLL Shield (A) Filter		GE-86D-6515
19	Fiber, PLL Shield (A) VCO		GE-86D-6514
20	Fiber, PLL Shield (B) IC		GE-86D-6517
21	Fiber, PLL Shield (B) VCO		GE-86D-6516
22	Case, PLL Shield (A)		GE-86D-6368
23	Case, PLL Shield (B)		GE-86D-6372
24	Case, PLL Shield (C)		GE-86D-6376
25	Top, PLL Shield (A)		GE-86D-6369
26	Top, PLL Shield (B)		GE-86D-6373
27	Plate, PLL Shield (D) VCO		GE-86D-6528
28	PCB Ass'y, Logic		GA-86D-6318
29	Case Logic Shield		GE-86D-6388
30	Top, Logic Shield		GE-86D-6389
31	Fiber, Logic Shield		GE-86D-6529
32 T801	Transformer, Power	TA-0127	GE-85D-5667
33	Box, Battery	DB-0741	GE-21D-5728
34	Cover, Battery Compartment	DB-0094	GE-79D-0113
35	Cushion, Battery		GE-21D-5795
36	Cord, AC 6.5 feet (UL)	W-3388	GE-86D-6312
37 SP801	Speaker 8 ohm 2W	SP-5374	SM-77KY-2
38	Bracket Speaker		GE-86D-6361
39	Mattress, Speaker		GE-86D-6505
40	Escutcheon Ass'y, Front (Non Repairable)	Z-1483	GA-86D-6385
	Escutcheon, Front		GE-86A-6354
	Protector, Escutcheon		GE-86C-6500
	Window, LCD		GE-86D-6355
41	PCB Ass'y, LCD		GA-86D-6319
42 LCD701	LCD		FTD-8200P
43	Electro Luminescence		GE-85D-6067
44	Holder, LCD		GE-85D-6386
45	Cushion, LCD		GE-85D-6521
46	Knob, Dimmer/Sound Squelch	K-1064	GE-86D-6357
47	Shield, LCD		GE-86D-6364
48	Fiber, LCD Shield		GE-86D-6365
49	PCB Ass'y, Keyboard		GA-86D-6320
50	Shield, Keyboard		GE-86D-6366
51	Fiber, Keyboard		GE-86D-6367
52	Plate, Ground		GE-86D-6509
53	Volume, Switch		5M1411-50KA-20A
54	Squelch, Volume		K1611008TE-10KC-20

Ref. No.	Description	RS Part Number	MFR's Part Number
55	Jack, Head Phone	J-1824	S-G8022#2
56	Knob, Volume/Squelch	K-1063	GE-86D-6356
57	Antenna, Telescopic	A-0083	GE-86D-6519
58	Foot	F-0054	OK-15
59	Panel, Keybaord	Z-1482	GE-86D-6358
60	Himelon (A)		GE-86D-6522
61	Himelon (B)		GE-86D-6523
62	Himelon (C)		GE-86D-6524
63	Himelon Speaker		GE-86D-6387
64	Screw, Panhead With Washer Ass'y Tind ZU		PM2.6x5
65	Screw, Panhead With Washer Ass'y ZU		PM3x6
66	Screw, Panhead P tight		PT2.6x5
67	Screw, Panhead Tapping		PT3x6
68	Screw, Panhead		PM3x6
69	Screw, Panhead Tapping		PT2.6x6
70	Screw, Panhead P tight		PT3x8
(A)	Screw, Bindinghead BLK		BM3x6
71	Screw, Bindinghead With Washer Ass'y ZU		BM3x12
72	Screw, Bindinghead	HD-1814	BM4x8
73	Screw, Bindinghead Tapping		BT3x6
74	Screw, Bindinghead		GE-79D-0541
75	Screw, Countersunkhead Machine	HD-2585	CM3x6
76	Washer, External Toothed Lock 3m/m		ETW 3m/m
77	Washer, Internal Toothed Lock 3m/m	HD-8966	ITW 3m/m
78	Nut, flange serrated		3 DIA
79	Nut, flange serrated		4 DIA
80	Nut		7 DIA
81	Nut, Grommet		
	Hardware Kit	HW-200019	#327(B)

APPENDIX

Variable parts for each model are below.

Ref. No.	Description	USA	CANADA	AUSTRALIA	UK
R214	Metal Film 3.3 ohm 1W ±0.5%	RNS1.0-3R3J	—	RNS1.0-3R3J	RNS1.0-3R3J
	Metal Film 3.3 ohm 1/2W ±0.5%	—	ERQ-12AJ-3R3	—	—
R235	Metal Film 1 ohm 1W ±0.5%	RSN1.0-010J	—	RNS1.0-010J	RNS1.0-010J
	Metal Film 2.2 ohm 1W ±0.5%	—	ERQ-1AJ-2R2	—	—
R801	Solid Film 1.8M ohm 1/2W ±10%	ERC-12GK-185	ERC-12GK-185	Not used	Not used
D512	1S2076A (Silicon)	Not used	Not used	1S2076A	1S2076A
T801	Transformer, Power Cord, AC	GE-85D-5667 GE-86D-6312	Z1643 GE-86D-6312	K7087 PZ-ACTF-LD-AS	K7087 HAR CLASS II BLK 2m
	Strainrelief, Line Cord Chassis	SR-3P-4 GE-86A-6359	SR-3P-4 GE-86A-6359	SR-5N-4 GE-86A-6359A	SR-4N-4 GE-86A-6359A

DISASSEMBLY / EXPLODED VIEW

Remove four screws (A) and detach the Cabinet (1)

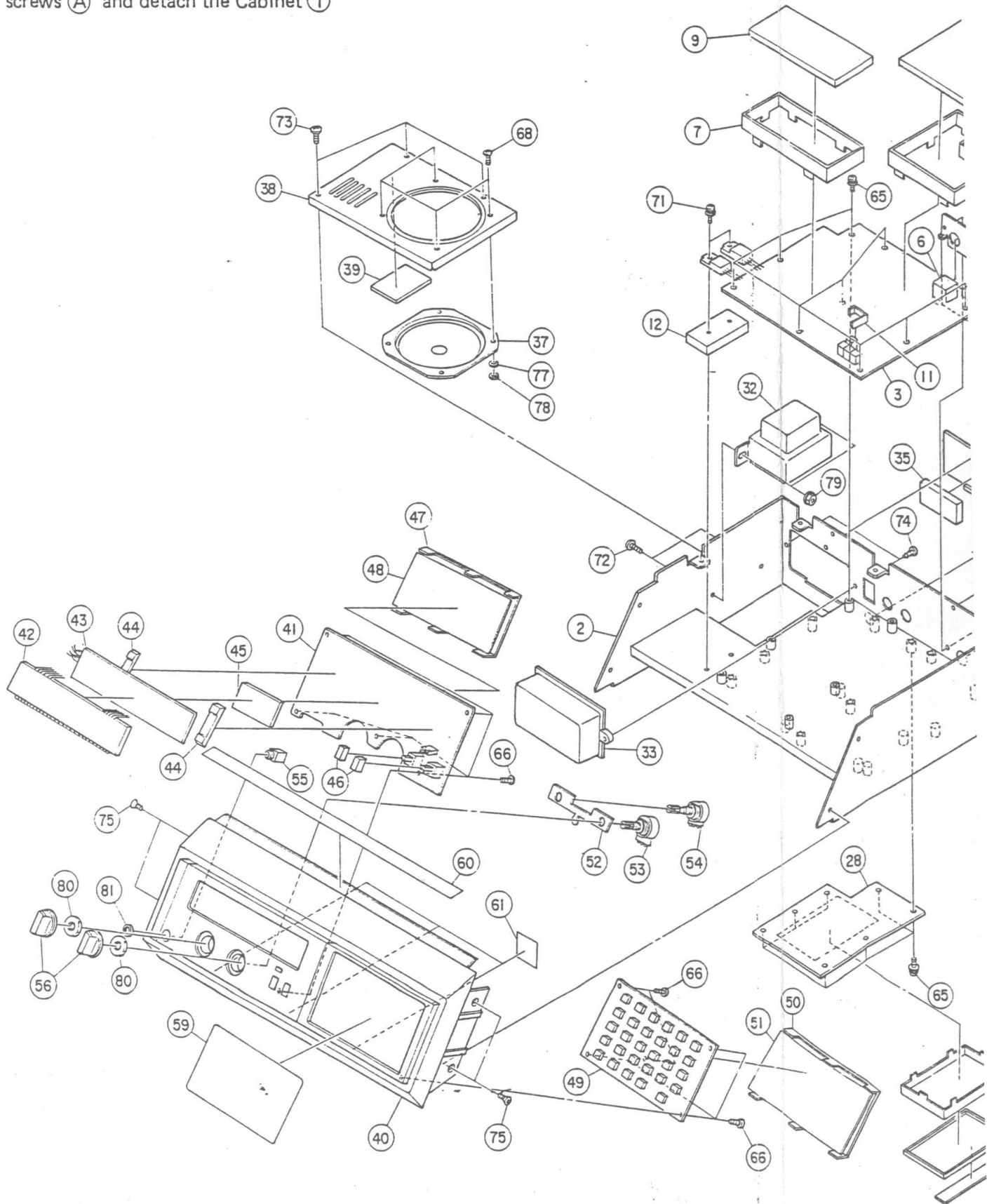

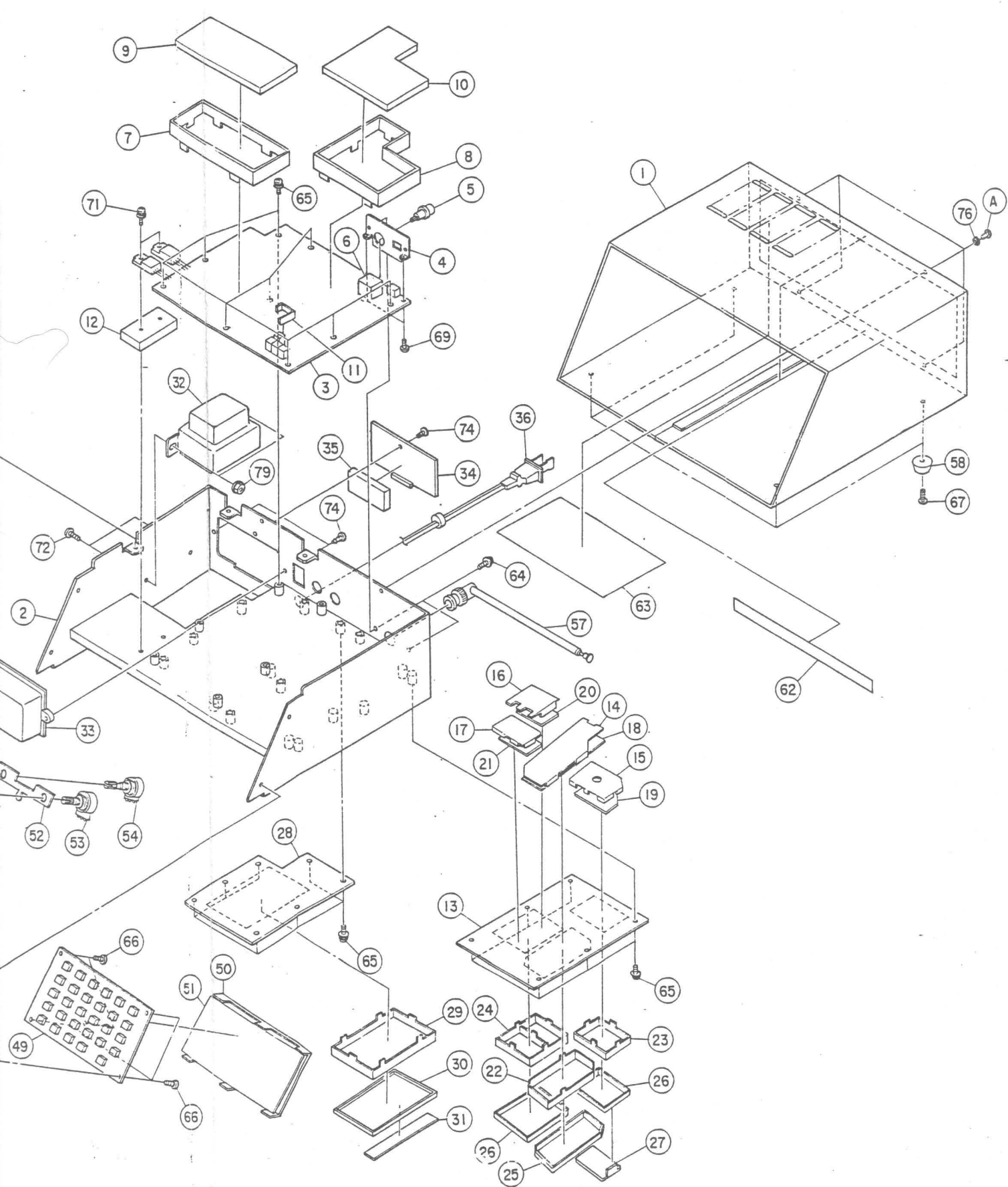

SEMICONDUCTOR LEAD IDENTIFICATION AND IC CIRCUIT DIAGRAM

INTEGRATED CIRCUIT LEAD IDENTIFICATION

IC1 K84419A

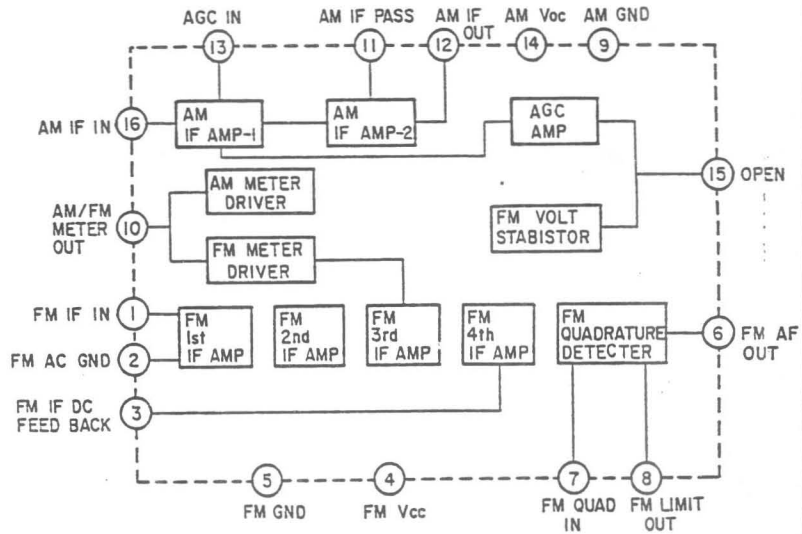
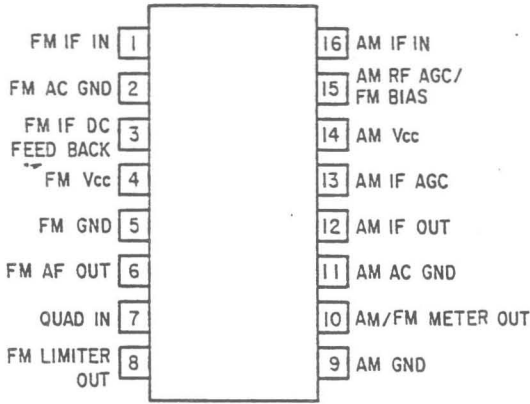

IC2 TK10420

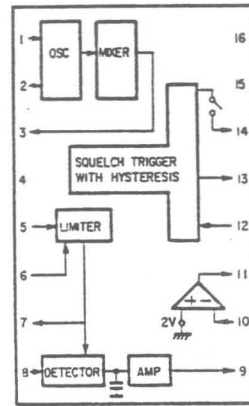
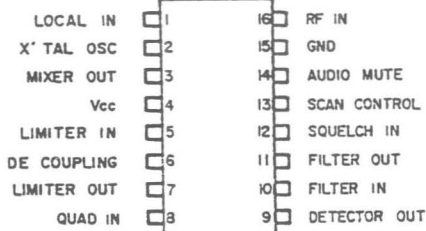

IC3 HD14011B

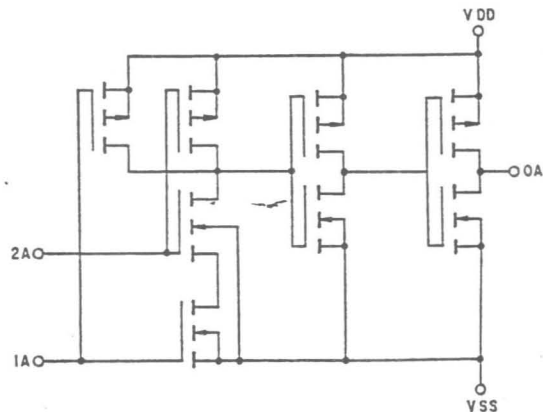
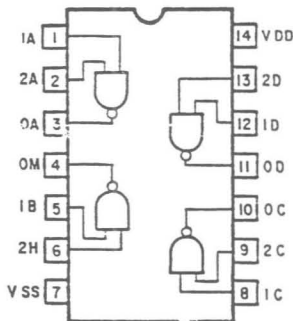

IC4 HD14066BP

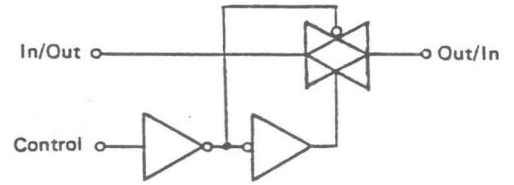
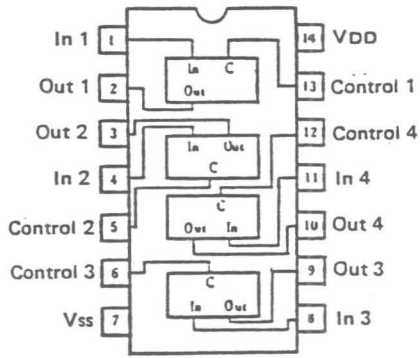

IC5, 6 μ PC324C

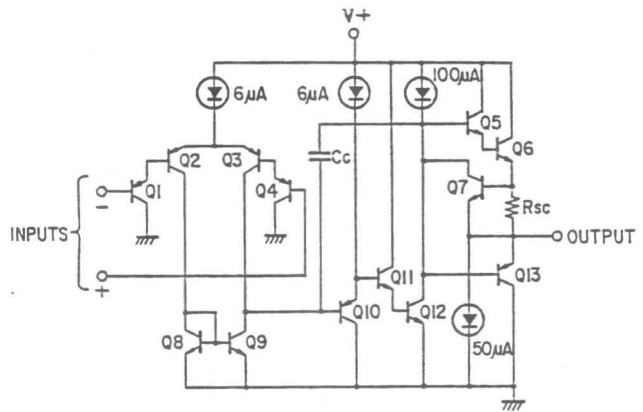
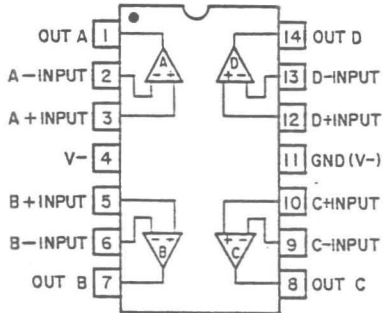

IC7 TDA1905

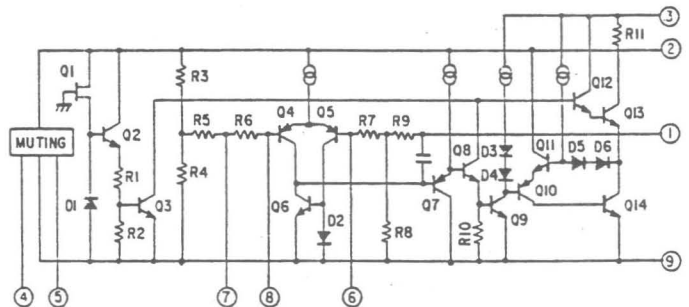
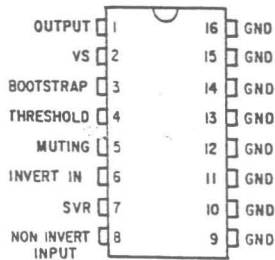

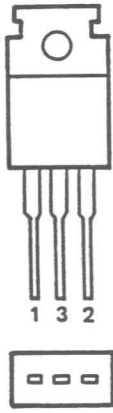

- 1. INPUT
- 2. OUTPUT
- 3. GND

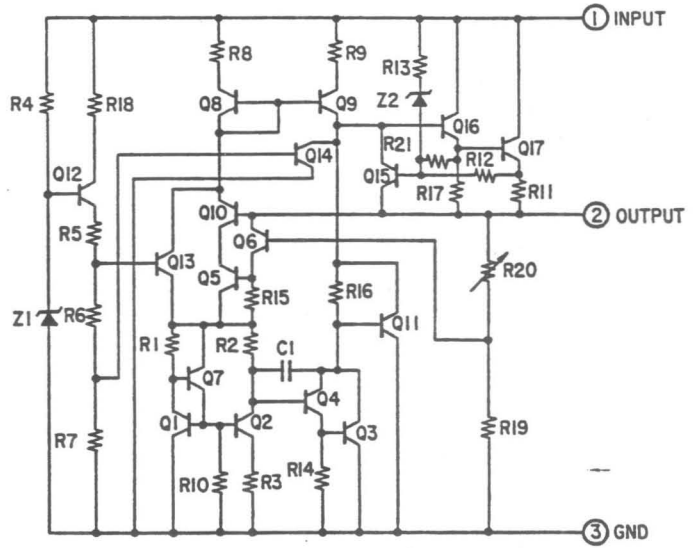

IC9 S-81250HG

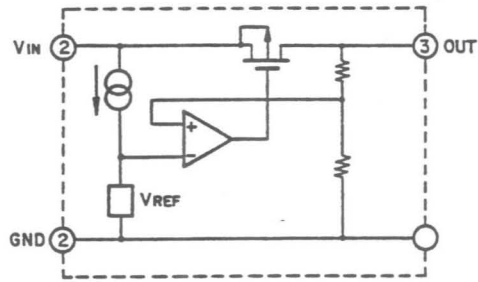
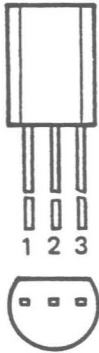

IC301 MC145158

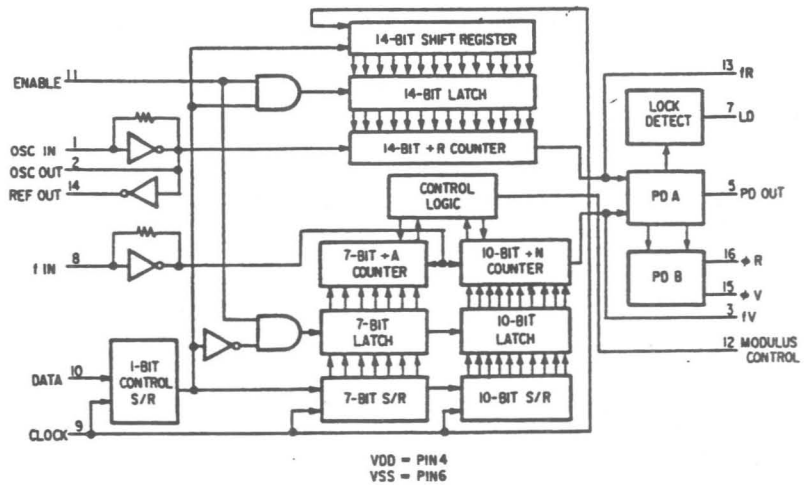
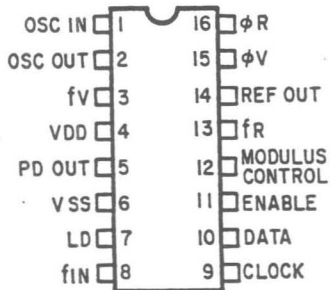

IC302 CX7925B

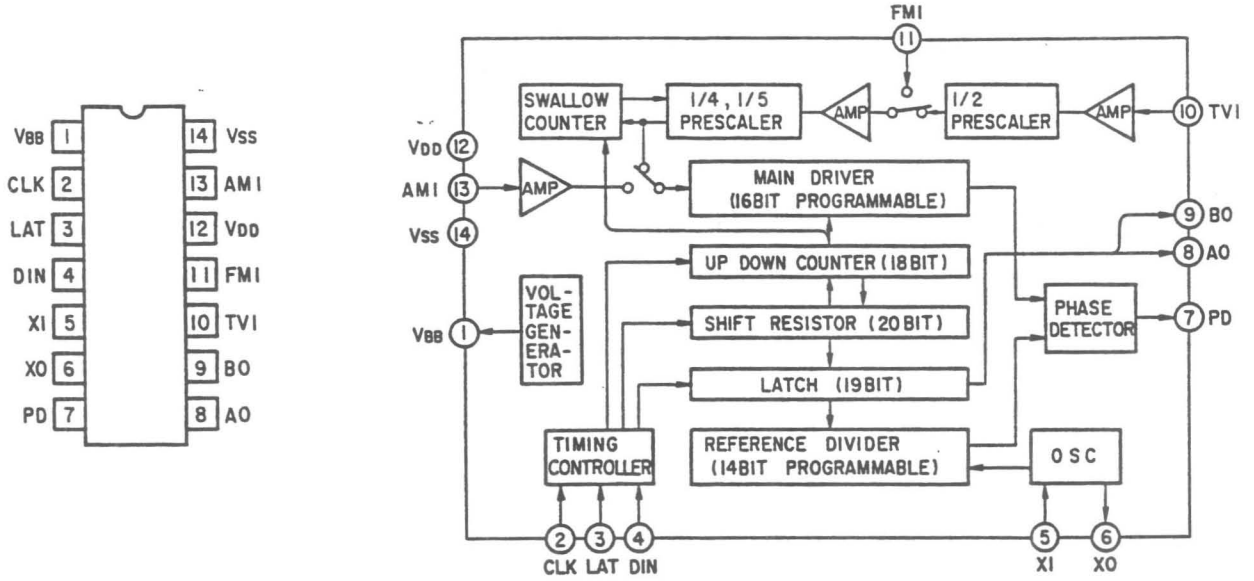

IC303 TD6127AP

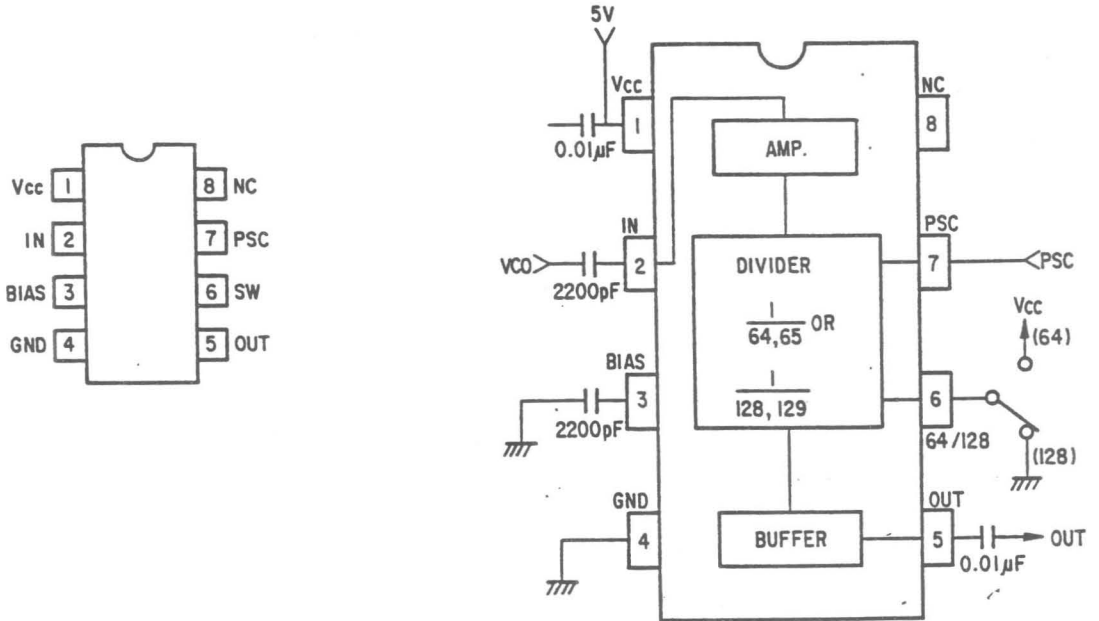

IC304 TD6105AP

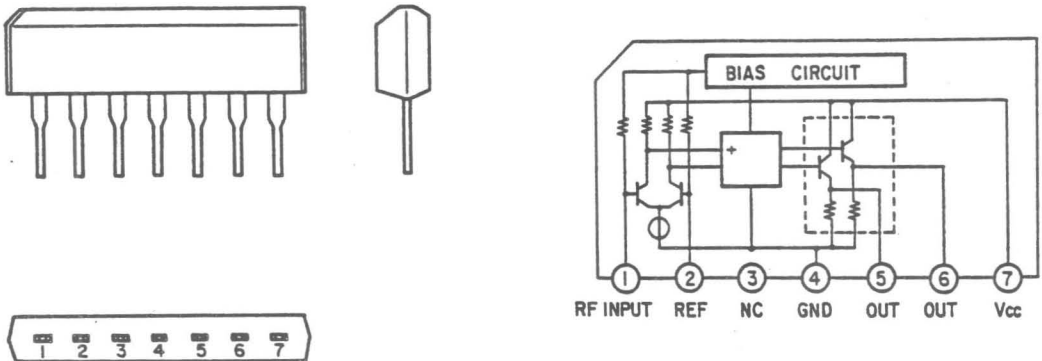

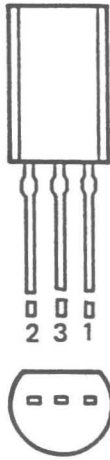

- 1. INPUT
- 2. OUTPUT
- 3. COMMON

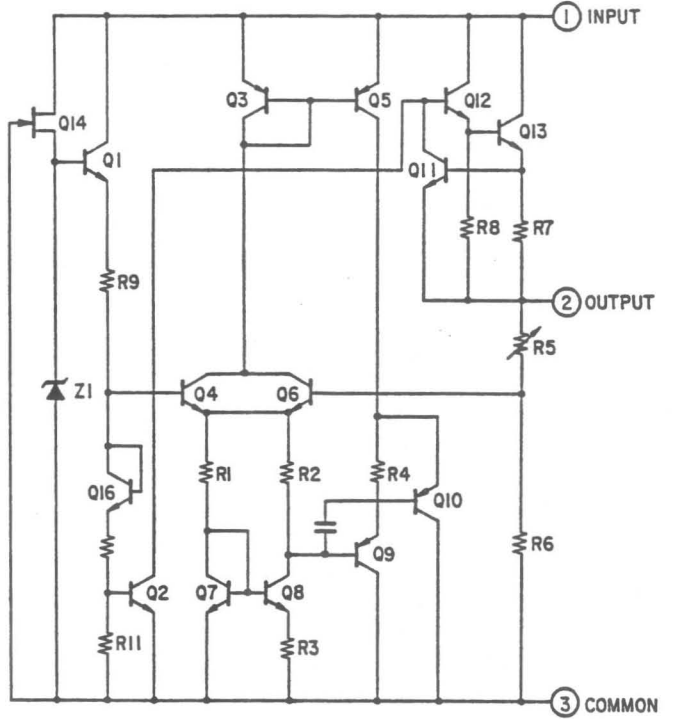

IC501 SN74LS145 or HD74LS145

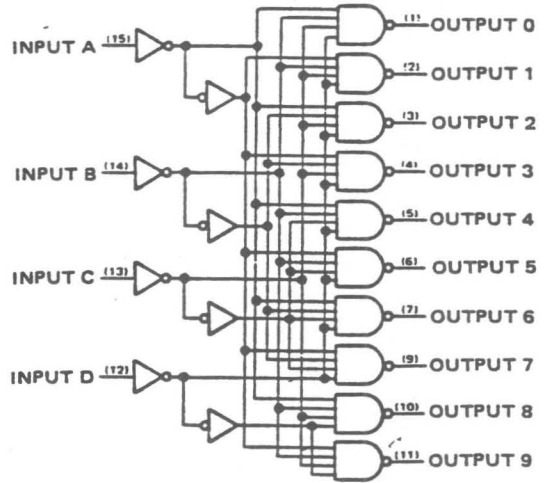
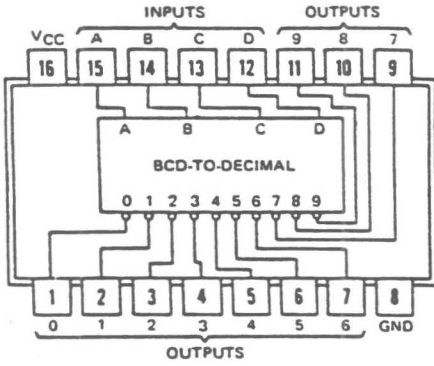

IC502 TD62504P

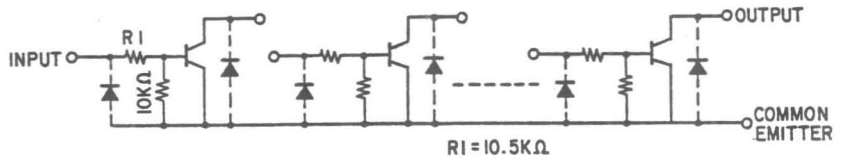
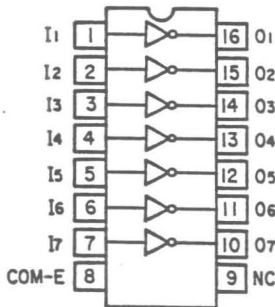

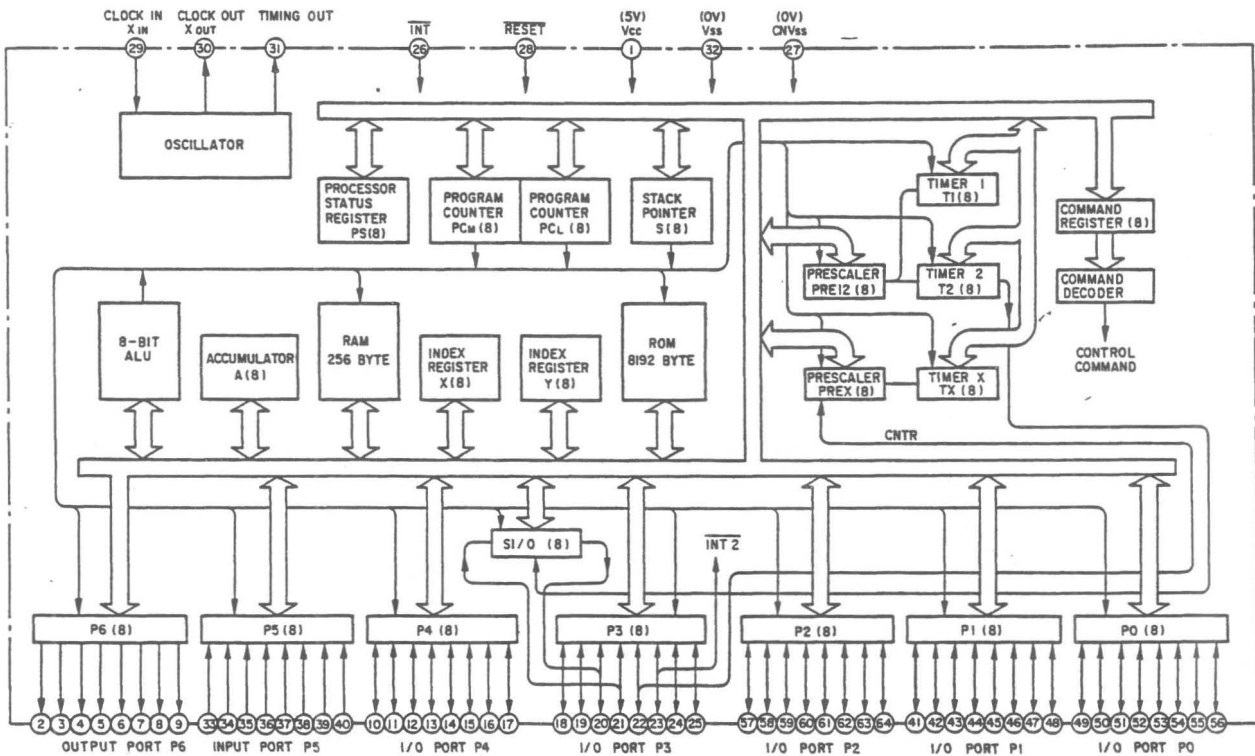
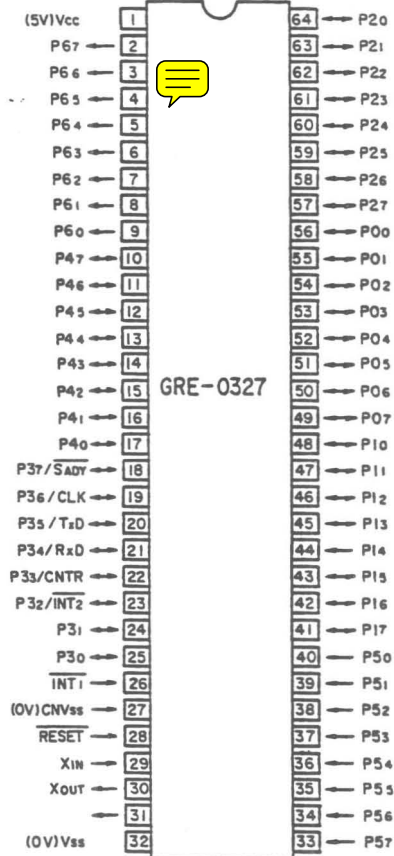

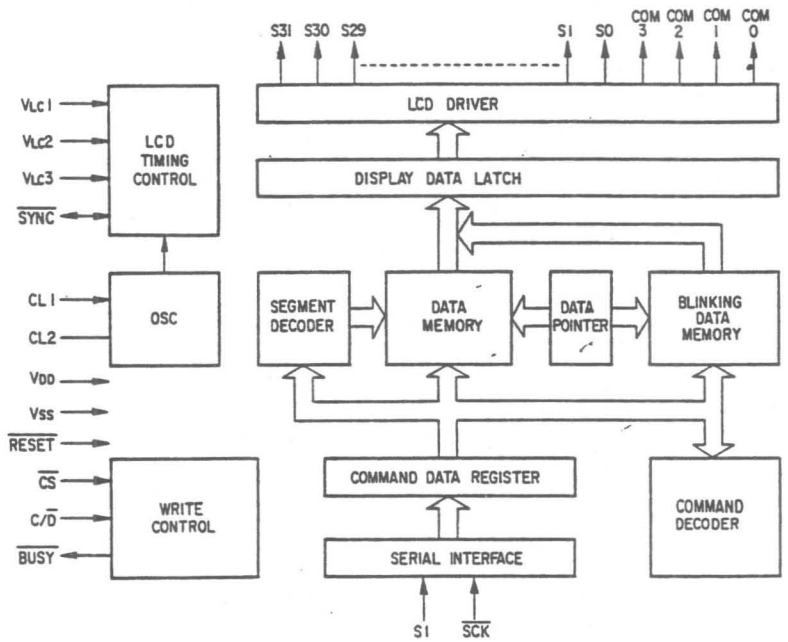
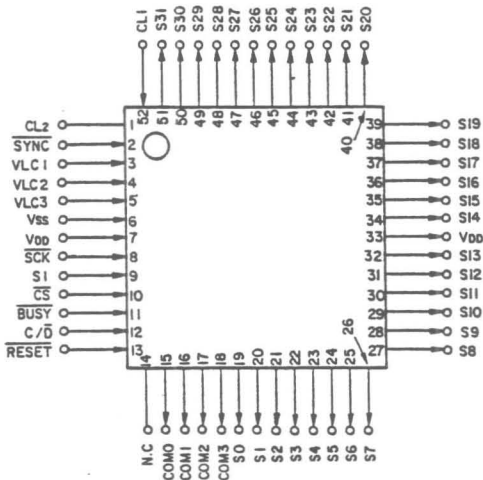
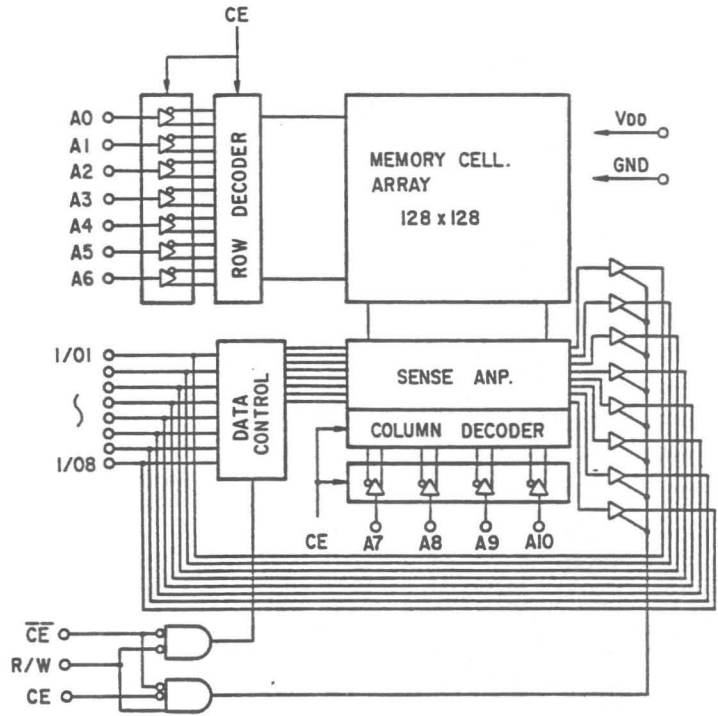
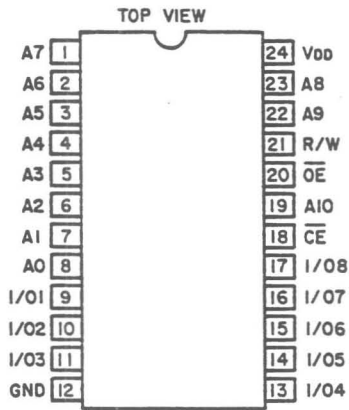

TRANSISTOR LEAD IDENTIFICATION

(A) 2SC2458(Y,GR)
2SC2458L(GR)
2SC2668(Y)
2SA1048
2SC3327
RN2201

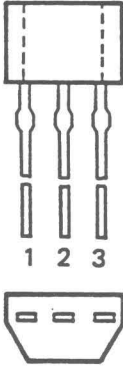

1. EMITTER
2. COLLECTOR
3. BASE

(B) 2SC3355



1. BASE
2. EMITTER
3. COLLECTOR

(C) 2SC3356

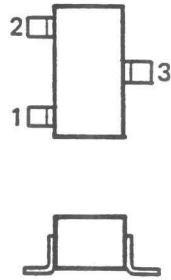

1. EMITTER
2. BASE
3. COLLECTOR

(D) 2SD1406

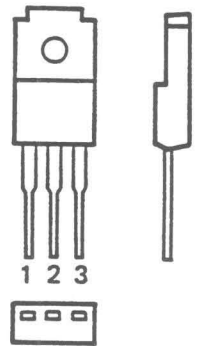

1. BASE
2. COLLECTOR
3. EMITTER

(E) 2SD1330

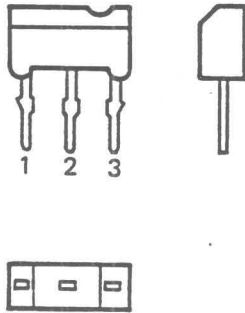

1. BASE
2. COLLECTOR
3. EMITTER

(F) 2SC3358

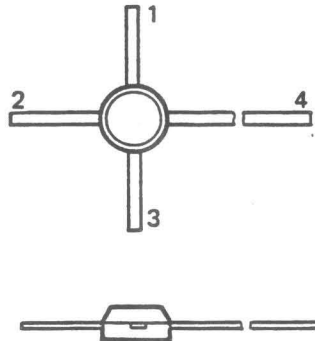

1. EMITTER
2. BASE
3. EMITTER
4. COLLECTOR

(G) 2SK184(GR)

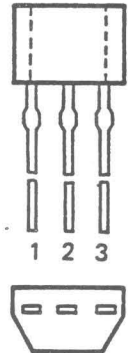

1. DRAIN
2. GATE
3. SOURCE

(H) 2SK194A(GR)

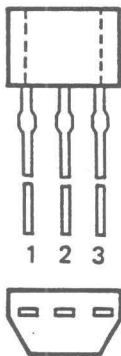

1. DRAIN
2. SOURCE
3. GATE

(I) 2SC945(AQ)

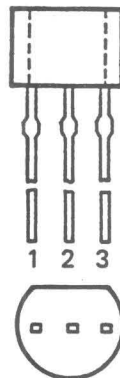

1. EMITTER
2. COLLECTOR
3. BASE

(J) RN2005

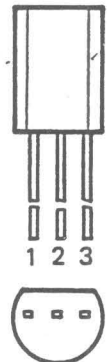

1. EMITTER
2. COLLECTOR
3. BASE

DIODE IDENTIFICATION AND LEAD POLARITY

A) 1SS241

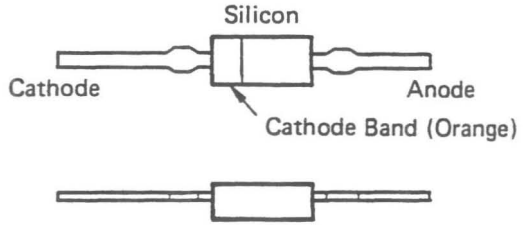

B) 1S2076A

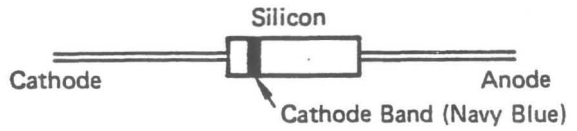

C) SR1K-2

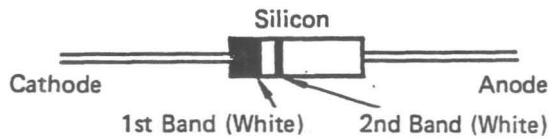

D) 1B4B41

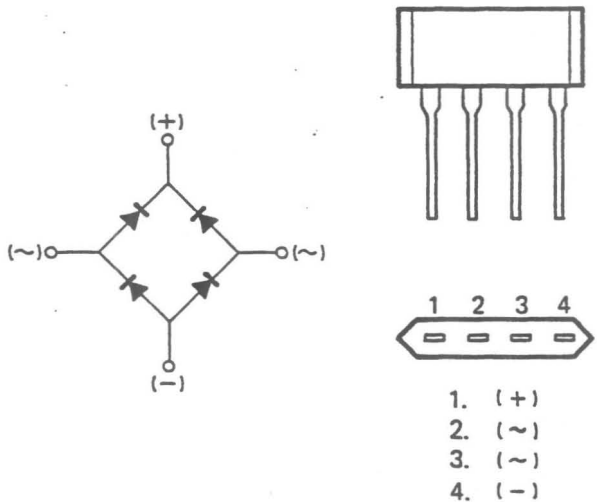

E) 1S1585

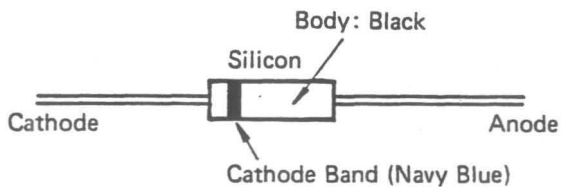

F) HZ6B2L, HZ9BLL
HZ11BLL

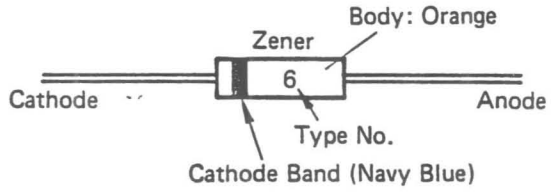

G) 1T25

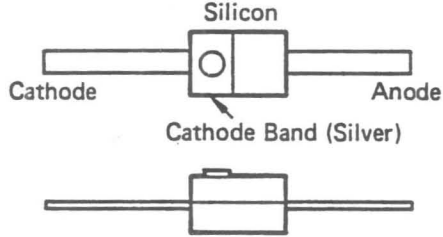

H) 1SV89

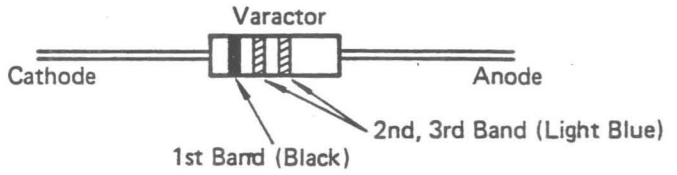

I) OA90-R

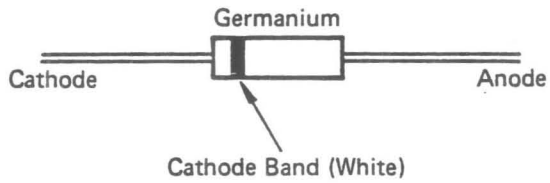

J) ND487CI-3R

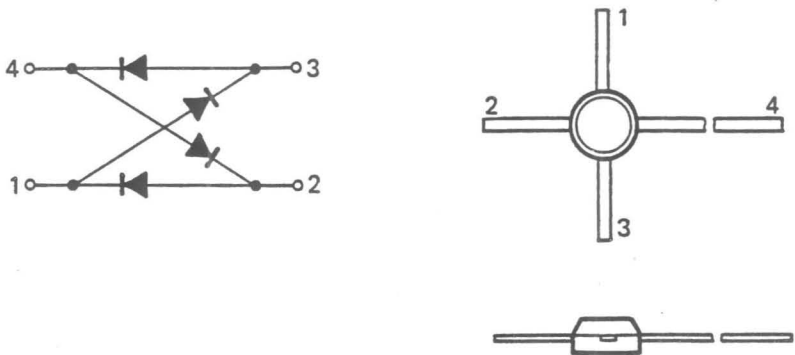

MICROPROCESSOR (IC-503) PIN ALLOCATION

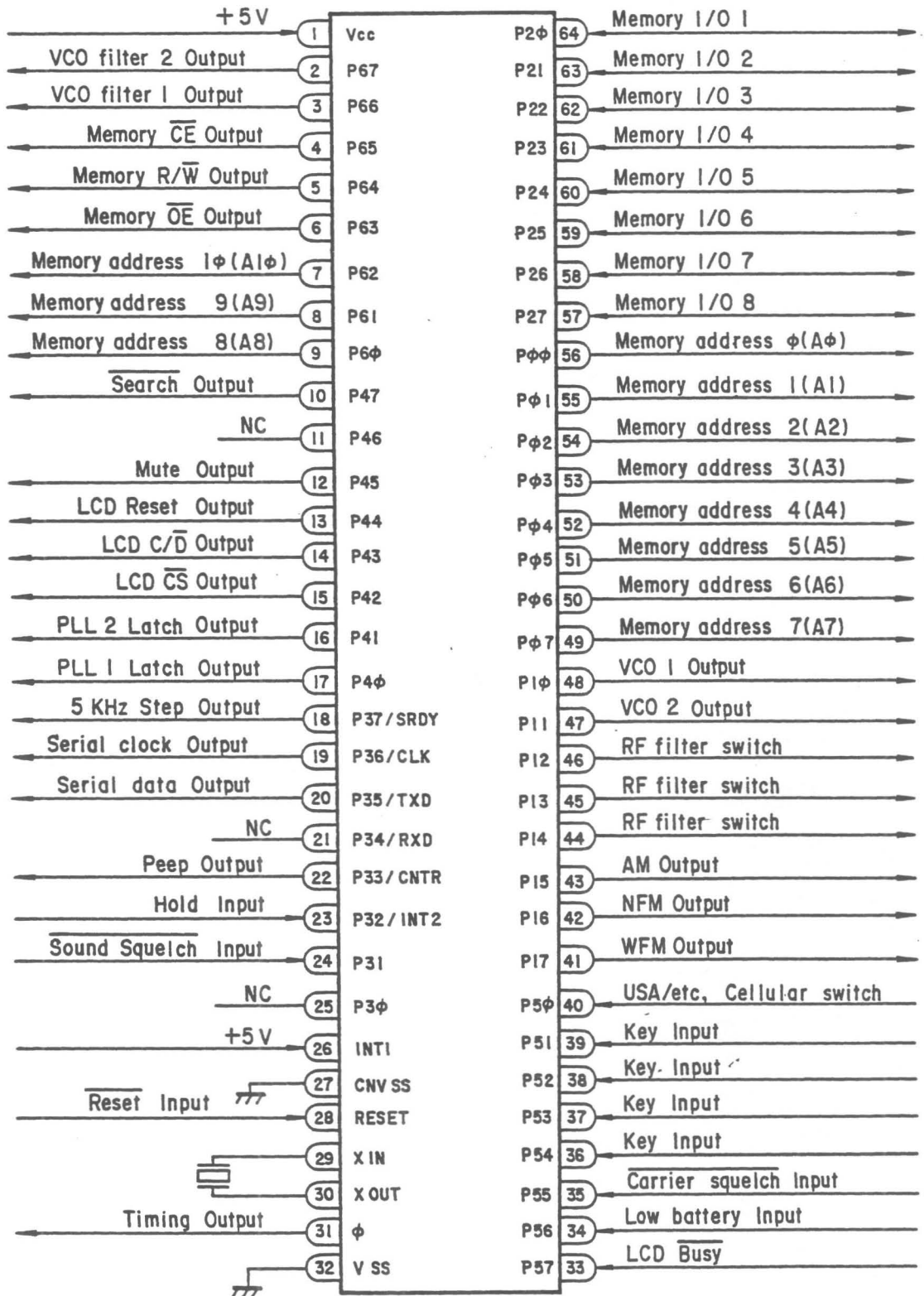

MICROPROCESSOR (IC-503) PORT FORMAT

Pin No.	Symbol	Function	Pin No.	Symbol	Function
1	VCC	+5 V	33	P57	LCD Busy
2	P67	VCO filter 2 Output	34	P56	Low battery Input
3	P66	VCO filter 1 Output	35	P55	Carrier Squelch Input
4	P67	Memory CE Output	36	P54	Key Input
5	P64	Memory R/W Output	37	P53	Key Input
6	P63	Memory OE Output	38	P52	Key Input
7	P62	Memory address 10 (A10)	39	P51	Key Input
8	P61	Memory address 9 (A9)	40	P50	USA/etc., Cellular Switch
9	P60	Memory address 8 (A8)	41	P17	WFM Output
10	P47	Search Output	42	P16	NFM Output
11	P46	NC	43	P15	AM Output
12	P45	Mute Output	44	P14	RF filter Switch
13	P44	LCD Reset Output	45	P13	RF filter Switch
14	P43	LCD C/D Output	46	D12	RF filter Switch
15	P42	LCD CS Output	47	P11	VCO 2 Output
16	P41	PLL 2 Latch Output	48	P10	VCO 1 Output
17	P40	PLL 1 Latch Output	49	P07	Memory address 7 (A7)
18	P37/SRDY	5 kHz Step Output	50	P06	Memory address 6 (A6)
19	P36/CLK	Serial Clock Output	51	P05	Memory address 5 (A5)
20	P35/TxD	Serial Data Output	52	P04	Memory address 4 (A4)
21	P34/RxD	NC	53	P03	Memory address 3 (A3)
22	P33/CNTR	Peep Output	54	P02	Memory address 2 (A2)
23	P32/INT2	Hold Input	55	P01	Memory address 1 (A1)
24	P31	Sound Squelch Input	56	P00	Memory address 0 (A0)
25	P30	NC	57	P27	Memory I/O 8
26	INT1	+5 V	58	P26	Memory I/O 7
27	CNVSS	GND	59	P25	Memory I/O 6
28	RESET	Reset Input	60	P24	Memory I/O 5
29	X _{IN}	Clock Input	61	P23	Memory I/O 4
30	X _{OUT}	Clock Output	62	P22	Memory I/O 3
31	φ	Timing Output	63	P21	Memory I/O 2
32	VSS	0 V	64	P20	Memory I/O 1

MICROPROCESSOR (IC-503) FUNCTION TABLE

(1) Outputs of VCO (P10, P11) and VCO filter (P66, P67)

Receiving Frequency (MHz)	VCO Output	VCO filter Output
25.0000 to 220.4950	VCO 1 (P10) "H"	VCO filter 1 (P66) "H" Level
220.5000 to 520.0000	VCO 2 (P11) "H"	
760.0000 to 1052.4950	VCO 1 (P10) "H"	VCO filter 2 (P67) "H" Level
1052.5000 to 1300.0000	VCO 2 (P11) "H"	

(2) Outputs of RF filter (P12, P13, P14)

Receiving Frequency (MHz)	P12	P13	P14
25.0000 to 39.9950	H	L	L
40.0000 to 67.9950	L	H	L
68.0000 to 107.9950	H	H	L
108.0000 to 173.9950	L	L	H
174.0000 to 279.9950	H	L	H
280.0000 to 520.0000	L	H	H
760.0000 to 1300.0000	H	H	H

(3) Outputs of Search (P47) and 5 kHz Step (P37)

		Search Output (P47)	5 kHz Step Output (P37)
MANUAL Operation		H	L
PROGRAM Operation		H	L
SCAN Operation		H	L
In SEARCH Operation	Receiving Frequency 25 to 520 MHz	at 5 kHz Step	L
		at Other Step	L
	Receiving Frequency 760 to 1300 MHz	at 5 kHz Step	L
		at Other Step	L

SCHEMATIC DIAGRAM (LINEAR SECTION)

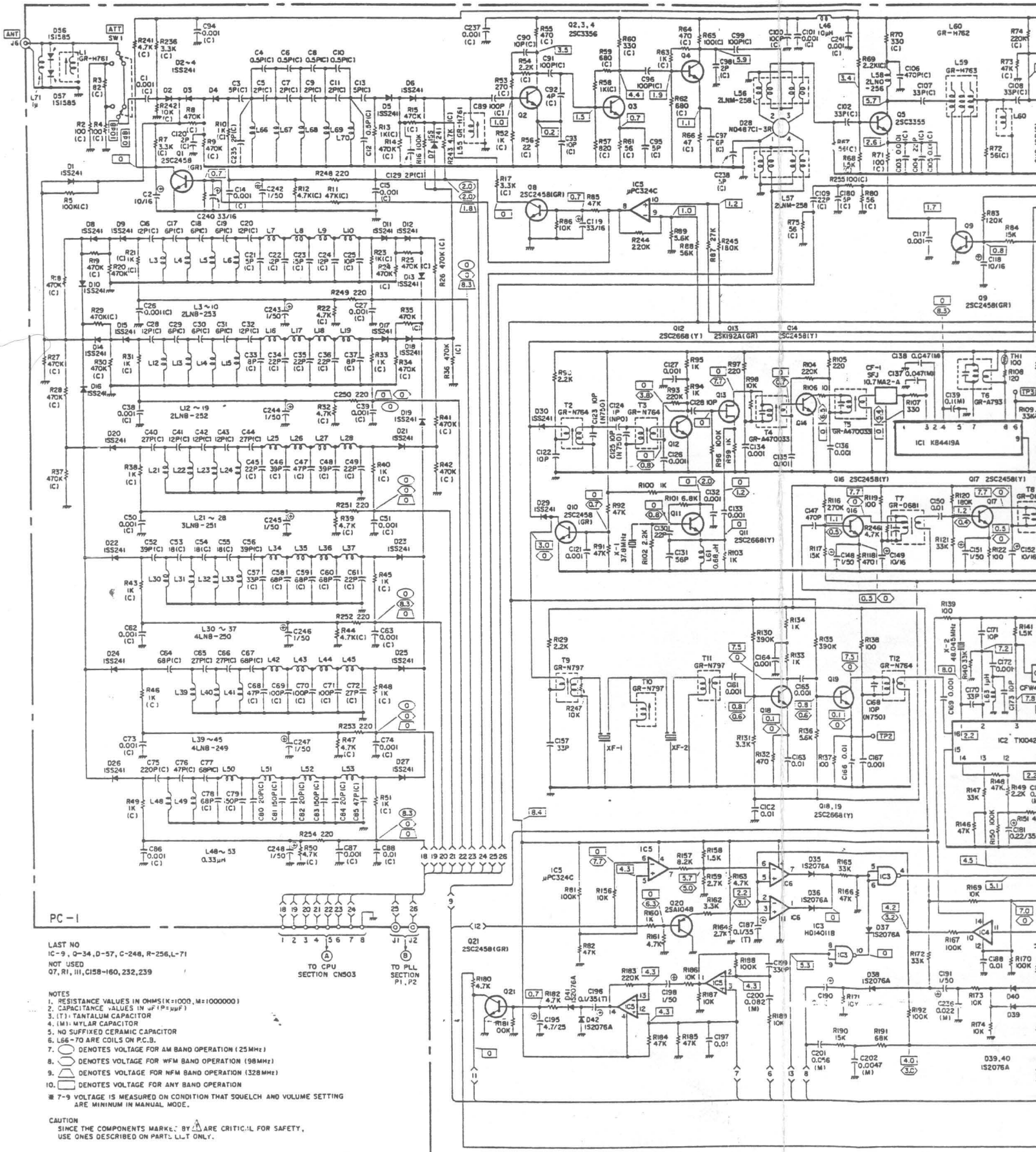

PC-1

LAST NO
IC-9, Q-34, D-57, C-248, R-256, L-71
NOT USED
Q7, R1, III, C158-160, 232, 239

- NOTES
1. RESISTANCE VALUES IN OHMS (K=1000, M=1000000)
 2. CAPACITANCE VALUES IN μF (P=PF)
 3. (T) TANTALUM CAPACITOR
 4. (M) MYLAR CAPACITOR
 5. NO SUFFIXED CERAMIC CAPACITOR
 6. L56-70 ARE COILS ON P.C.B.
 7. ○ DENOTES VOLTAGE FOR AM BAND OPERATION (25MHz)
 8. □ DENOTES VOLTAGE FOR WFM BAND OPERATION (98MHz)
 9. ▽ DENOTES VOLTAGE FOR NFM BAND OPERATION (328MHz)
 10. △ DENOTES VOLTAGE FOR ANY BAND OPERATION
- 7-9 VOLTAGE IS MEASURED ON CONDITION THAT SQUELCH AND VOLUME SETTING ARE MINIMUM IN MANUAL MODE.

CAUTION
SINCE THE COMPONENTS MARKED BY ▲ ARE CRITICAL FOR SAFETY,
USE ONES DESCRIBED ON PARTS LIST ONLY.

SCHEMATIC DIAGRAM (CPU S

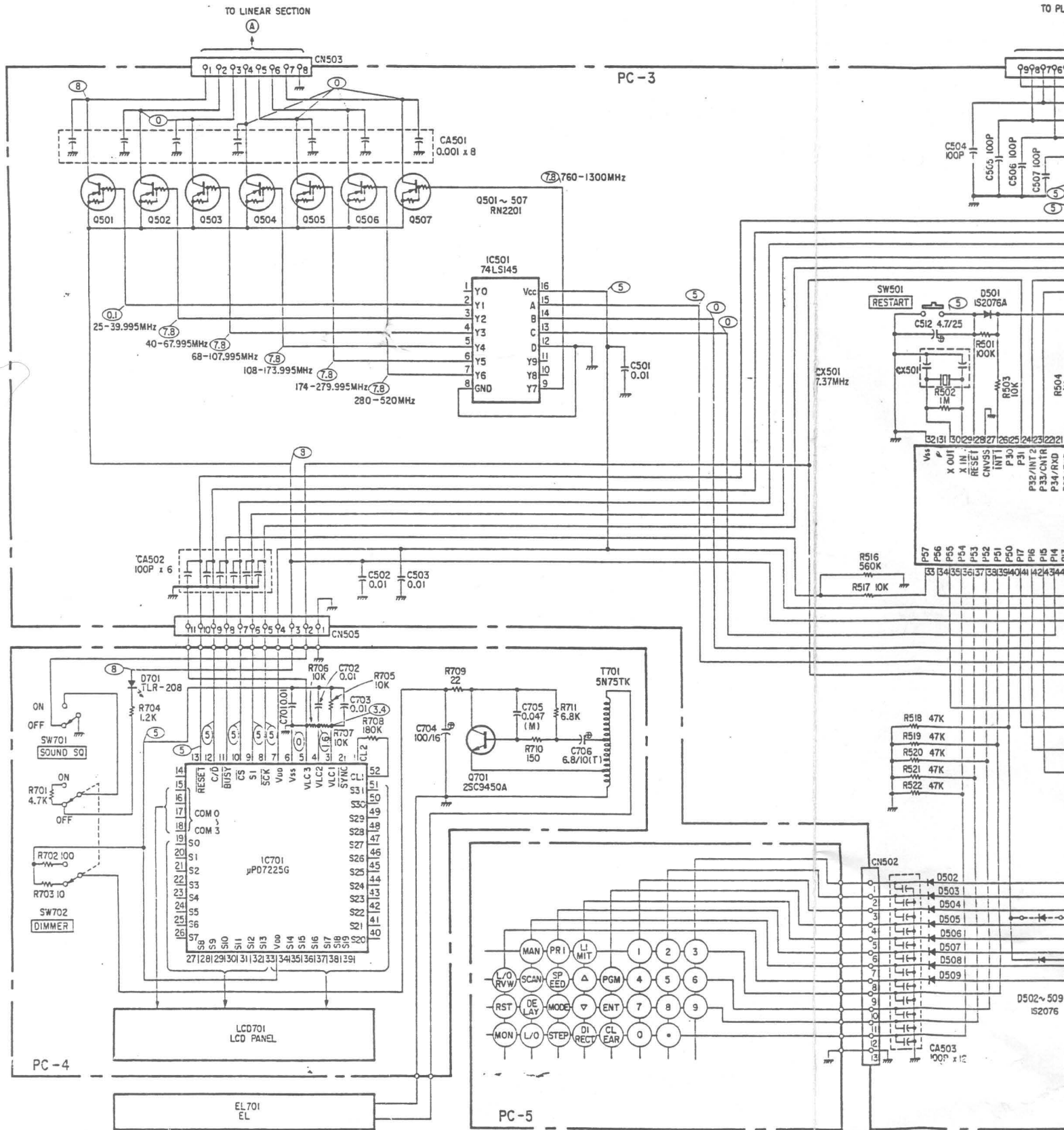

NOTES: 1. RESISTANCE VALUES IN OHMS (K=1000, M=1000000)
 2. CAPACITANCE VALUES IN µF (P=µµF)
 3. (T): TANTALUM CAPACITOR
 4. (M): MYLAR CAPACITOR
 5. NO SUFFIXED CERAMIC CAPACITOR
 6. (V) DENOTES DC VOLTAGE MEASURED WITH DC VOLTMETER (100KΩ/V)
 UNDER FOLLOWING CONDITIONS CH 1 LOW BAND AT 25MHz AM MANUAL
 OPERATION. VOLUME AT MINIMUM AND SQUELCH CCW.

LAST NO.	LOGIC	LCD	NOT USED
IC-504	IC-701	D510, 511, 513, 514	
Q-507	Q-701	C513, 514	
O-515	D-701	≠ D512	FOR EUROPE
C-519	C-706		
R-522	R-711		

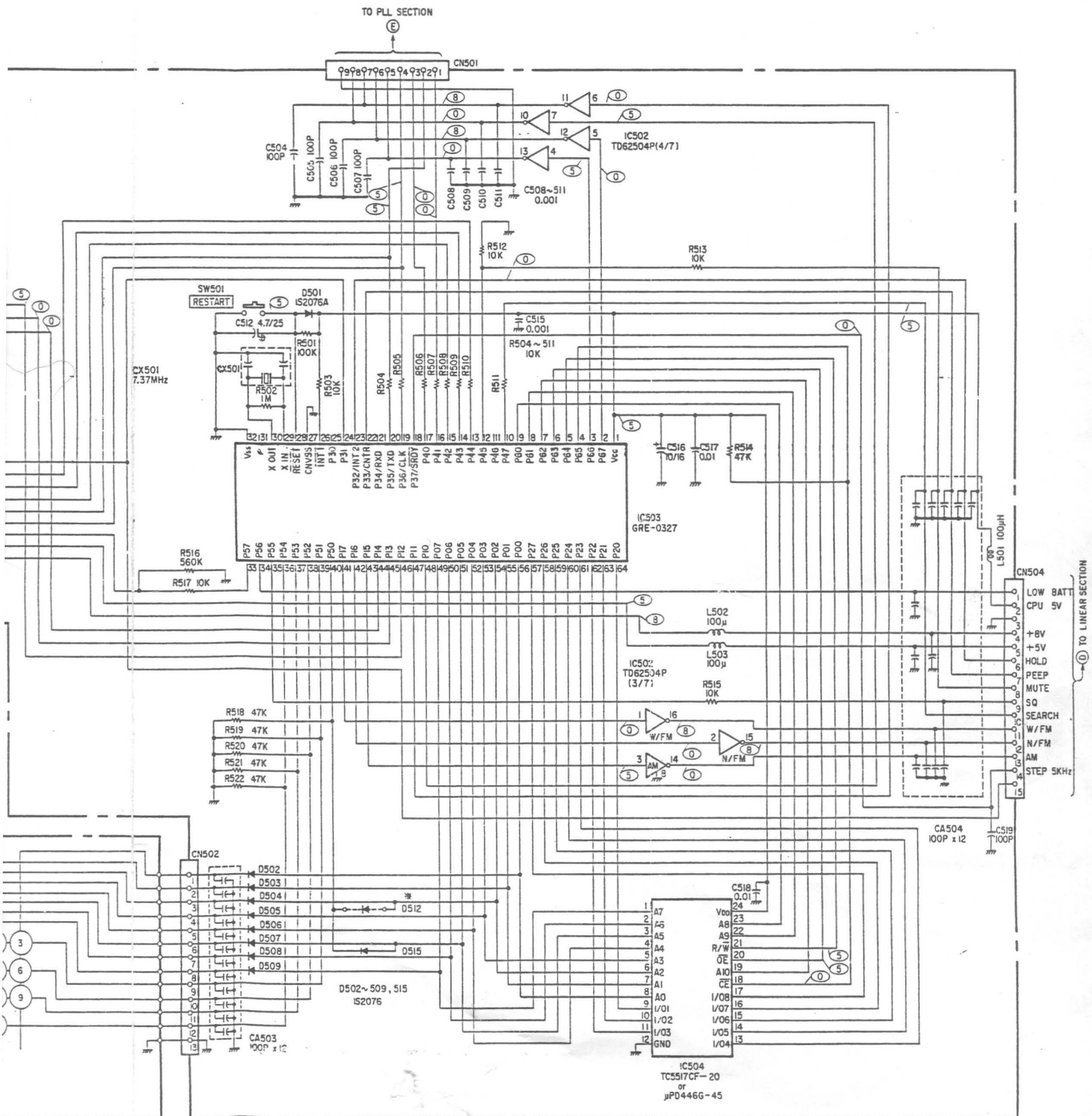

DO, M=1000000
)
 ED WITH DC VOLTMETER (100K Ω /V)
 LOW BAND AT 25MHz AM MANUAL
 IND SQUELCH CCW.

LAST NO.
 LOGIC LCD
 IC-504 IC-701
 Q-507 Q-701
 D-515 D-701
 C-519 C-706
 R-522 R-711

NOT USED D510, 511, 513, 514
 CAUTION: SINCE THE COMPONENTS MARKED BY Δ ARE CRITICAL FOR SAFETY, USE ONES DESCRIBED ON PARTS LIST ONLY.
 * D512 FOR EUROPEAN/AUSTRALIAN MODELS ONLY

Copyright 1986

